

2020

## ANALYTICAL STUDY FOR THE COMPATIBILITY OF ANTHROPOMETRIC DESIGN OF EDUCATIONAL FURNITURE IN THE FACULTY OF PHYSICAL THERAPY AT DELTA UNIVERSITY

Amira H. Mohammed  
*Delta University for Science and Technology*

Saad N. F  
*Delta University for Science and Technology*

Ahmed Y. M  
*Delta University for Science and Technology*

Mohammed A. S  
*Delta University for Science and Technology*

Maher M. E  
*Delta University for Science and Technology*

Follow this and additional works at: <https://digitalcommons.aaru.edu.jo/dusj>



Part of the [Medicine and Health Sciences Commons](#)

---

### Recommended Citation

Mohammed, Amira H.; F, Saad N.; M, Ahmed Y.; S, Mohammed A.; and E, Maher M. (2020) "ANALYTICAL STUDY FOR THE COMPATIBILITY OF ANTHROPOMETRIC DESIGN OF EDUCATIONAL FURNITURE IN THE FACULTY OF PHYSICAL THERAPY AT DELTA UNIVERSITY," *Delta University Scientific Journal*: Vol. 3 : No. 2 , Article 2.

Available at: <https://digitalcommons.aaru.edu.jo/dusj/vol3/iss2/2>

This Article is brought to you for free and open access by Arab Journals Platform. It has been accepted for inclusion in Delta University Scientific Journal by an authorized editor. The journal is hosted on [Digital Commons](#), an Elsevier platform. For more information, please contact [rakan@aar.edu.jo](mailto:rakan@aar.edu.jo), [marah@aar.edu.jo](mailto:marah@aar.edu.jo), [dr\\_ahmad@aar.edu.jo](mailto:dr_ahmad@aar.edu.jo).



## ANALYTICAL STUDY FOR THE COMPATIBILITY OF ANTHROPOMETRIC DESIGN OF EDUCATIONAL FURNITURE IN THE FACULTY OF PHYSICAL THERAPY AT DELTA UNIVERSITY

Amira H. Mohammed<sup>1</sup>., Saad. N. F<sup>2</sup>, Ahmed. Y. M<sup>2</sup>, Mohammed. A. S<sup>2</sup>, Maher. M. E<sup>2</sup>.

<sup>1</sup>Assistant Professor in Department of Physical Therapy for Pediatric Disorders, Faculty of Physical Therapy, Delta University for Science and Technology, Egypt.

<sup>2</sup>Student in Faculty of Physical Therapy, Delta University for Science and Technology, Egypt.

### Abstract:

One of the main objectives in Egyptian State strategic plan 2030 was to develop the health system and develop new methods of treatment and disease prevention. So the idea of our research project was to determine the effect of university furniture on the functional performance of the upper and back limbs and the measurement of pain ratio for all neck and lower back. The first topic in this project is the Analytical study of the compatibility of the design of human measurements for users of university educational furniture. This study aimed to analyze the compatibility of anthropometric design of educational furniture in the Faculty of Physical Therapy at Delta University. Fifty-eight students participated in this study from all sexes (36 males and 22 females) with age ranged from 18 to 21 years. Their body mass index ranged from 18.5 to 24.9 kg/ m<sup>2</sup>. They were divided into three groups (group I, group II and group III) based on the type of educational furniture be used. All subjects in three groups and the educational furniture were conducted for anthropometric measurements by using Tape measurement. The educational furniture dimensions and the user furniture dimensions were used to define the range in which each furniture dimensions is considered ergonomically appropriate. The results of this study represented significant incompatibility in the three types of the educational furniture with highly mismatching for the stool type (group III). We could conclude that there is incompatibility of anthropometric design of educational furniture used in the Faculty of Physical Therapy at Delta University.

**Keywords:** Anthropometric, design, educational furniture.

### Introduction

Young youth spend from five to seven hour per day assuming sitting position in university life [1]. There are different types of university furniture designs. Each one of these design should be meet the ergonomic principles to be healthier [2, 3]. The mismatching of university furniture design contributes to the several musculoskeletal problems including muscle spasm, neck pain and incorrect posture [4-9].

In the Faculty of Physical Therapy at Delta University for Science and Technology, there are three types of educational furniture used by students. The first type was used in lectures hall (fig 1a). The second type was used in practical sections (fig 1b). Finally, the third type used in laboratory labs (fig 1c). So, this study aimed to analyze the compatibility of anthropometric design of educational furniture in the Faculty of Physical Therapy at Delta University for Science and Technology based on ergonomic principles.



Figures (1a, 1b &1c): Types of educational furniture in the Faculty of Physical Therapy at Delta University for Science and Technology.

## 1. Subject and methods

### 1.1. Subjects

Fifty eight students participated in this study from all sexes (32 males and 22 females) with age ranged from 18 to 21 years. Their body mass index ranged from 18.5 to 24.9 kg/ m<sup>2</sup>. They were divided into three groups (group I, group II and group III) based the type of educational furniture be used. This study was conducted in the period from February 2019 to April 2019.

They were recruited from several study levels in Faculty of Physical Therapy at Delta University for Science and Technology, Egypt, according to the following criteria:

- Group I: Twenty two students from all sexes (13 males and 9 females) used the first type of educational university furniture used in lectures hall (fig 1a).
- Group II: Nineteen students from all sexes (11 males and 8 females) used the second type of educational university furniture used in practical sections (fig 1b).
- Group III: Seventeen students from all sexes (12 males and 5 females) used the third type of educational university furniture used in laboratory labs (fig 1c).
- Subjects in all groups did not have injuries in neck, back, upper or lower limb.
- Subjects in all groups did not have a history of inflammatory joint disease, surgical intervention for neck, back, upper or lower limb.

- Subjects in all groups did not have a history of neuropediatric or developmental disorders.

- Subjects in all groups were not athletes.

Students had signed a consent form about the purpose of the study, its benefits and inherent risks, their committee with regard to time and money and Agreement to participate.

### 1.2. Instrumentations

#### 1.2.1. Tape measurement

It was used to determine the subject's dimensions and educational furniture dimensions in centimeters (cm).

#### 1.2.2. Weight scale

It was used to determine the weight for every subject in kilograms (kg).

### 1.3. Procedures

After Subject permission, the subject conducted the following procedures:

- **Detection of the subject's weight and body mass index (BMI)**
  - The tape measurement was installed on the wall by using pins. The stature was determined as the vertical distance between the floor and the top of the head and measured with the subject standing erect against the wall and looking straight ahead, <sup>[10]</sup>.
  - After the stature of the subject's had been measured, the subject was asked to stand on a weight scale to determine his weight in kilograms. The BMI was calculated as the ratio of the subject's

height (in meter) and weight (in kilogram) i.e. weight/ height<sup>2</sup>. The normal subject's BMI value should range from 18.5 to 24.9 kg/ m<sup>2</sup>, [11].

• **Detection of the subject's dimensions and educational furniture dimensions**

- All dimensions were taken after four hour from the starting of the day use of the educational furniture for each type.
- The subjects assumed sitting position on the educational university furniture with the standardized instruction: “knee and elbow bent at 90°, feet supported on the floor and look straight ahead”, fig (2 a), [12].

- The user furniture dimensions were measured as mentioned in table (1), fig (2a), [12].

• **Relationship between educational furniture dimensions and the user body dimensions**

The educational furniture dimensions and the user furniture dimensions were used to define the range in which each furniture dimensions is considered appropriate. It was done according to the following five ergonomics equations table (3), [12]:

Table (1): The user- furniture dimensions (sitting position).	
Item	Definition
Elbow seat height (EH)	Measured with the elbow flexed at 90°, as the vertical distance from the bottom of the tip of the elbow to the student’s seated surface
Shoulder height (H)	Measured as the vertical distance from the top of the shoulder at the acromion process to the student’s sitting surface.
Upper arm length (UAL)	Difference between the elbow height and shoulder height.
Knee height (KH)	Measured with knee flexed at 90°, as the vertical distance from the foot resting surface to be top of the knee cap, just above the patella.
Popliteal height (PH)	Measured with a 90°, knee flexion, from the foot resting surface to the popliteal space, which is the posterior surface of the knee
Buttock-popliteal length (thigh length) BPL	Measured with the knee flexed at 90°, as the distance from the posterior surface of the buttock to the posterior surface of the knee or popliteal surface.

Table (2): The educational furniture dimensions (sitting position).	
Item	Definition
Seat height (SH)	Measured as a distance from the floor to the highest point on the front of the seat.
Seat depth (STD)	Measured from the back of the sitting surface of the seat to its front.
Backrest height (BH)	The vertical distance from the desk seat to the top edge of backrest.
Desk–seat height (DH)	The vertical distance from the seat to the top of the front edge of the desk.
Under-surface of desk height (UDH)	The vertical distance from the floor to the bottom of the front edge of the shelf under the writing surface.

- Educational furniture dimensions (desk and bench) dimensions were measured

as mentioned in table (2), fig (2b), [12].

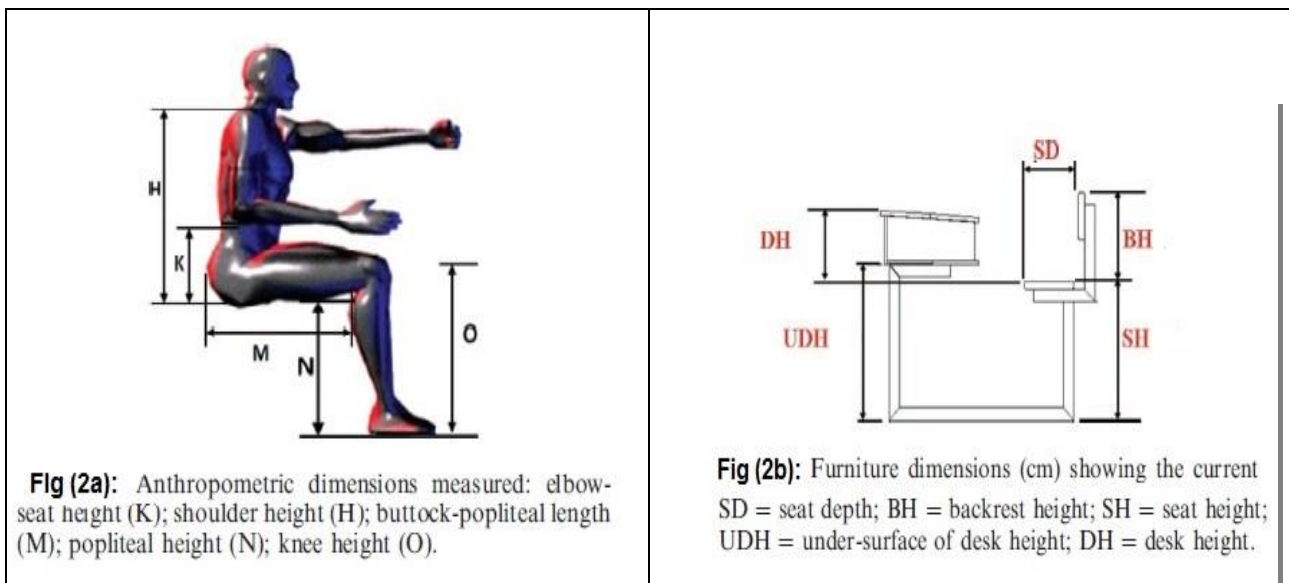

Table (3): Relationship between educational furniture dimensions and the user body dimensions

No	Relation	Ergonomics equation
1	Seat height to popliteal height	$(N + 2) \cos 30^\circ \leq SH < (N + 2) \cos 5^\circ$ Where SH is seat height and N is popliteal height.
2	Seat depth to the popliteal- buttock length	$80\%M \leq SD < 95\%M$ Where SD is seat depth and M is popliteal- buttock length.
3	Backrest height	$60\% H \leq BH < 80\% H$ Where BH is backrest height and H is shoulder height (scapula height).
4	Desk height	$K + (N + 2) \cos (30) \leq DH < (N + 2) \cos (5) + 0.8517K + 0.1483 H$ Where DH is desk height, K is elbow- seat height, N is popliteal height and H is shoulder height.
5	Under-surface of desk height	$(O + 2) + 2 \leq UDH$ Where UDH is the under-surface of desk height and O is the knee height.

#### 1.4. Statistical analysis

The mean value and standard deviation were calculated for each variable measured during the study. The percentage of compatibility for each item of the educational furniture dimensions to the user furniture dimensions was calculated.

## 2. Results

### 2.1. Descriptive data of three groups

The distribution of males and females in the group (I) was 53.8% and 46.2%; respectively. The distribution of males and females in the group (II) was 46.4 % and 53.6%; respectively.

Also, the distribution of males and females in the group (III) was 75% and 25%; respectively. The mean values  $\pm$  standard deviations of the age, height, weight, body mass index (BMI) and the subject's dimensions indicated were

represented in table (4). The mean values  $\pm$  standard deviations of the educational furniture dimensions indicated were represented in table (5).

Table (4): Descriptive analysis for the age, height, weight, body mass index (BMI) and the subject's dimensions three groups.

Item	Mean values $\pm$ standard deviations			significance
	Group I	Group II	Group III	
Age	19.50 $\pm$ 0.60	19.21 $\pm$ 0.85	19.47 $\pm$ 0.51	0.344
Height	171.55 $\pm$ 9.83	168.37 $\pm$ 10.34	172.59 $\pm$ 7.62	0.363
Weight	65.80 $\pm$ 9.97	61.00 $\pm$ 8.48	66.32 $\pm$ 8.45	0.121
Body mass index (BMI)	22.16 $\pm$ 2.20	21.37 $\pm$ 1.64	22.58 $\pm$ 1.45	0.137
Elbow seat height (EH)	26.00 $\pm$ 3.37	21.11 $\pm$ 3.51	24.53 $\pm$ 4.32	0.000*
Shoulder height (H)	58.73 $\pm$ 3.68	53.89 $\pm$ 2.66	58.59 $\pm$ 4.21	0.000*
Upper arm length (UAL)	32.82 $\pm$ 4.79	32.79 $\pm$ 4.59	34.06 $\pm$ 4.16	0.636
Knee height (KH)	50.05 $\pm$ 7.94	52.21 $\pm$ 2.74	53.65 $\pm$ 2.62	0.114
Popliteal height (PH)	46.73 $\pm$ 4.23	46.58 $\pm$ 2.97	51.35 $\pm$ 4.26	0.000*
Buttock-popliteal length (thigh length) BPL	47.41 $\pm$ 2.68	46.37 $\pm$ 3.77	47.62 $\pm$ 4.56	0.540

\*significant.

## 2.2. The percentage of compatibility for each item of the educational furniture dimensions to the user furniture dimensions

The percentage of compatibility for each item of the educational furniture dimensions to the user furniture dimensions, table (6).

Table (5): Descriptive analysis for the subject's dimensions and educational furniture dimensions in three groups.

Item	Mean values $\pm$ standard deviations		
	Group I	Group II	Group III
Seat height (SH)	44.00 $\pm$ 0.00	47.50 $\pm$ 0.00	58.00 $\pm$ 0.00
Seat depth (STD)	33.00 $\pm$ 0.00	42.50 $\pm$ 0.00	0.00 $\pm$ 0.00
Backrest height (BH)	31.00 $\pm$ 0.00	38.50 $\pm$ 0.00	0.00 $\pm$ 0.00
Desk-seat height (DH)	32.00 $\pm$ 0.00	26.00 $\pm$ 0.00	33.00 $\pm$ 0.00
Under-surface of desk height (UDH)	72.00 $\pm$ 0.00	72.00 $\pm$ 0.00	72.00 $\pm$ 0.00

Table (6): Relationship between educational furniture dimensions and the user body dimensions

Relation	Group I		Group II		Group III	
	No	Per	No	Per	No	Per
Compatible	11	50%	12	63.16	0	0%

Seat height to popliteal height					%		
	Incompatible	11	50%	7	36.84%	17	100%
Seat depth to the popliteal-buttock length	Compatible	0	0%	13	68.42%	0	0%
	Incompatible	22	100%	6	31.58%	17	100%
Backrest height	Compatible	1	4.55%	1	5.26%	0	0%
	Incompatible	21	95.55%	18	94.74%	17	100%
Desk height	Compatible	1	4.55%	0	0%	0	0%
	Incompatible	21	95.55%	19	100%	17	100%
Under-surface of desk height	Compatible	22	100%	19	100%	17	100%
	Incompatible	0	0%	0	0%	0	0%

### 3. Discussion

This study is the first topic in our research project to determine the effect of university furniture on the functional performance of the upper and back limbs and the measurement of pain ratio for all neck and lower back. It was conducted to analyze the compatibility of anthropometric design of educational furniture in the Faculty of Physical Therapy at Delta University. The age of the subjects participated in this study ranged from eighteen to twenty one years old as it represented the age of university life. The result of this study showed that there were no significant differences between the mean values of the age, height, weight and body mass index (BMI) in all groups which supported there were matching between all groups. Also, the results of this study represented significant differences in the Elbow seat height (EH), Shoulder height (H)

and Popliteal height (PH) while there were no significant differences between the mean values of the Upper arm length (UAL), Knee height (KH) and Buttock-popliteal length (thigh length) BPL. The results of this study showed that there was significant incompatibility of anthropometric design of educational furniture in the Faculty of Physical Therapy at Delta University. The relation of the seat height to popliteal height was incompatible in the group (I) by 50%, the group (II) by 36.84% and the group (III) by 100%; respectively. The relation of the seat depth to the popliteal-buttock length was incompatible in the group (I) by 100%, the group (II) by 31.58% and the group (III) by 100%; respectively. The relation of the backrest height was incompatible in the group (I) by 95.55%, the group (II) by 94.74% and the group (III) by 100%; respectively. The relation of the desk height was incompatible in the group (I) by 95.55%, the group (II) by



100% and the group (III) by 100%; respectively.

The relation of under-surface of desk height was compatible in all three groups by 100%.

These incompatibilities in the most of anthropometric designs of educational furniture may be had undesirable impact on the musculoskeletal system, posture and respiratory system in our youth. These results come in agreement with Mandal <sup>[13]</sup> in his research stated that students complained of pains in the back, neck or shoulder for which they blamed the furniture. A mismatch between thigh length and seat depth was significantly related to seating discomfort, and that a mismatch in the seated elbow height and the table height was significantly related to pain in the shoulders and neck <sup>[14, 15]</sup>.

### Conclusion

There is incompatibility of anthropometric design of educational furniture used in the Faculty of Physical Therapy at Delta University.

### 4. References:

- 1- Parcels, C., M. Stommel and R. P. Hubbard, "Mismatch of classroom furniture & student body dimensions: Empirical findings & health implications," *Journal of Adolescent Health*, 24, 265–273 (1999).
- 2- Mohamed Thariq, M. G., H. P. Munasinghe and J. D. Abeysekara,

"Designing chairs with mounted desktop for university students: Ergonomics and comfort," *International Journal of Industrial Ergonomics*, 40, 8–18 (2010).

3- Shah, R. M., M. A. U. Bhuiyan, R. Debnath, M. Iqbal and A. Shamsuzzoha, "Ergonomics issues in furniture design: A case of a tabloid chair design," In A. Azevedo (ed), *Advances in Sustainable and Competitive Manufacturing Systems, Lecture Notes in Mechanical Engineering*, Springer, 91–103 (2013).

4- Jeong, B. Y. and K. S. Park, "Sex differences in anthropometry for school furniture design," *Ergonomics*, 33, 1511–1521 (1990).

5- Lee, A., K. K. Tsang, S. H. Lee and C. Y. To, "Older school children are not necessarily healthier: Analysis of medical consultation pattern of school children from a territory-wide school health surveillance," *Public Health*, 115, 30–37 (2001).

6- Murphy, S., P. Buckle and D. Stubbs, "A cross-sectional study of self-reported back and neck pain among English schoolchildren and associated physical and psychological risk factors," *Applied Ergonomics*, 38, 797–804 (2007).

7- Trevelyan, F. C. and S. J. Legg, "The prevalence and characteristics of back pain among school children in New

Zealand,” *Ergonomics*, 53, 1455–1460 (2010).

8- Westgaard, R. H. and A. Aarås, “Postural muscle strain as a causal factor in the development of musculo-skeletal illnesses,” *Applied Ergonomics*, 15, 162–174 (1984).

9- A.S.M. Hoque, M.S. Parvez, P.K. Halder & T. Szecsi: Ergonomic design of classroom furniture for university students of Bangladesh, *Journal of Industrial and Production Engineering*, (2014). DOI: 10.1080/21681015.2014.940069.

10- Castellucci. I, Gonçalves. M. A and Arezes. P. M.: Ergonomic Design of School Furniture: Challenges for the Portuguese Schools. *Applied human factors and ergonomics*, 2010, 3rd international conference, USA.

11- Sethi. J, Sandhu. J. S and Vijay. I. V.: Effect of Body Mass Index on work related musculoskeletal discomfort and occupational stress of computer workers in a developed ergonomic setup. *Sports Medicine, Arthroscopy, Rehabilitation, Therapy & Technology*, 2011; 3:22.

12- Agha. S. R. (2010): School furniture match to students’ anthropometry in the Gaza Strip. *Ergonomics*, Vol. 53(3): 344–354.

13- Mandal, A. C. (1985): *The seated man (Homo sedens)*, Klampenborg, Demark; Dafnia publications.

14- Evans, O., Collins, B. and Stewart, A. (1992): ‘Is school furniture responsible for student seating discomfort? In: Hoffman, E., Evans, O. (Eds.)’, *Proceedings of the 28th Annual Conference of the Ergonomics Society of Australia ‘Unlocking Potential for the Future Productivity and Quality of Life’*, 31-37, Melbourne.

15- Grimes, P. and Legg, S. (2004): ‘Musculoskeletal disorders (MSD) in students as a risk factor for adult MSD: a review of the multiple factors affecting posture, comfort, and health in classroom environments’, *Journal of the Human Environmental System*, 7, 1–9.