

2019

Design and producing blowing mold using Additive manufacturing

Youssef R. Hassan

Packaging Materials Department, National Research Centre, youssef.refaat100@gmail.com

Mohamed A. El Farahaty

Printing, publishing and packaging department, Faculty of applied arts, Helwan University, mohamed2attia@hotmail.com

Saber Ibrahim Ibrahim

Packaging Materials Department, National Research Centre, youssef.refaat100@gmail.com

Mona A. Nassar

Packaging Materials Department, National Research Centre, youssef.refaat100@gmail.com

Follow this and additional works at: <https://digitalcommons.aaru.edu.jo/faa-design>



Part of the [Art and Design Commons](#)

Recommended Citation

Hassan, Youssef R.; El Farahaty, Mohamed A.; Ibrahim, Saber Ibrahim; and Nassar, Mona A. (2019) "Design and producing blowing mold using Additive manufacturing," *International Design Journal*: Vol. 9 : Iss. 4 , Article 6.

Available at: <https://digitalcommons.aaru.edu.jo/faa-design/vol9/iss4/6>

This Article is brought to you for free and open access by Arab Journals Platform. It has been accepted for inclusion in *International Design Journal* by an authorized editor. The journal is hosted on [Digital Commons](#), an Elsevier platform. For more information, please contact rakan@aarj.edu.jo, marah@aarj.edu.jo, dr_ahmad@aarj.edu.jo.

Design and producing blowing mold using Additive manufacturing

Prof. Mohamed A. El Farahaty

Printing, publishing and packaging department, Faculty of applied arts, Helwan University.

Prof. Mona A. Nassar

Packaging Materials Department, National Research Centre

Ass. Prof. S. Ibrahim

Packaging Materials Department, National Research Centre

Youssef R. Hassan

Packaging Materials Department, National Research Centre

Abstract:

The application of additive manufacturing (AM) technologies is becoming established in an increasing number of product development sectors. In this present work the advanced AM techniques was applied to blowing mold design and production. Its aim is to do a comprehensive analysis on what AM is doing for the recent and future perspectives in the field of mold's production. Furthermore, analyses were done on the possible use of Rapid Tooling (RT) techniques based on AM technologies. The aim of this work is to design and preparation blowing mold by polymer AM technique as Fused Deposition Modeling (FDM) for their use and validation in bottle production .

Keywords:

*Additive Manufacturing
Blowing Mold
Design Process
3D Printing*

Paper received 8th August 2019, Accepted 7th September 2019, Published 1st of October 2019

1. Introduction

The concepts of blow molding are a process used to produce hollow objects from thermoplastic. The basic blow molding process has two fundamental phases. The first one is a parson (or a perform) of hot plastic resin in a somewhat tubular shape is created. Additionally, the second included,

compressed air is used to expand the hot perform and press it against mold cavities. The pressure is held until the plastic cools. **Figure 1** illustrated the blow molding process is used for which has thin wall sections (K.Stoekhert and G.Menning1998, M. Gierak, 1998).

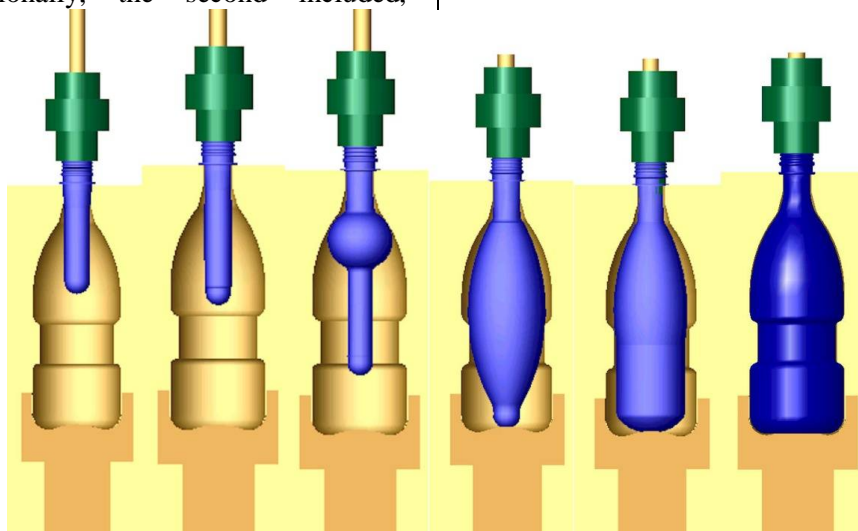

Figure 1: Stretch blow molding, the polymer is first heated to above the glass transition temperature. Then polymer is inflated and stretched with a hollow core-rod.

Blow mold design with CAD software. Molds are manufactured in traditional ways using metal or aluminum and CNC drilling, which represents a large cost and time show in **Figure 2**. New

method using 3D printing FDM to manufactured blowing mold will show in this article. (Campbell et al, 2012)

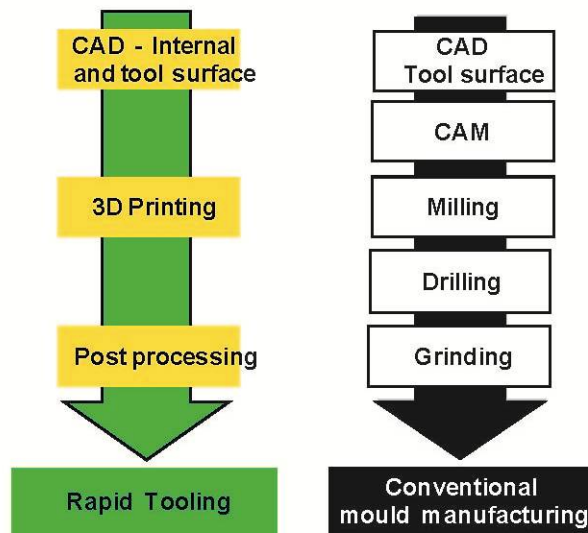

Figure 2: Conventional mold manufacturing and rapid tooling

Traditionally, production tools are constructed from metals such as steel or aluminum. This comes with a high cost and time commitment for

the manufacturing of the tools shown as **Figure 3.** (E. Alfredo Campo, 2006)



Figure 3: CNC milling metal blowing mold

Additive manufacturing (AM), also known as 3D printing, can create plastic tools that potentially alleviate this burden for both prototyping and short production runs by emulating the quality of parts

produced in metal tools as cleared in **Figure 4.** (Dalgarno and Stewart, 2001, Ferreira and Mateusb, 2003, Norwood et al, 2004).



Figure 4: Fused Deposition Modeling 3d printer

Numerous polymers can be used to create both the | tool and the molded plastic part (M. Gierak,

1998). In addition to, the with the utilization of AM tools, numerous designs can be created at low cost to test a variety of materials. Prior research suggests tools can be used to create between 10-100 parts for either analysis or distribution for short runs (Formlabs, 2016- Stratasys ,2016).

1.2. Research problems:

- High cost of mold manufacturing with conventional method
- Problem with mold after manufacturing

1.3. Research Objectives and Importance:

- New method to manufacturing mold appropriate with short run production

2. Experimental

The aim of this article was to evaluate the possibility of using a Rapid Tooling mold made by Fused Deposition Modelling technology to test the correct design of a Blowing mold product or to

make a short run production.

2.1. Materials

- Blue PLA filaments for FDM printing was purchased from commercial source.

2.2. Computer-aided design (CAD)

Also known as computer-aided design and drafting (CADD), is the use of computer technology for the process of design and design-documentation.

3. Design

3.1. Bottle Design

These kinds of packaging bottle products are available at the market in many designs and colors **Figure 5**. The consumption of bottles is growing due to increased products and market needs of new designs on a regular basis, which contributes to increased sales.



Figure 5:The plastic bottle at the market

According to the above-mentioned designs, a new design of the plastic bottle was created. In **Figure 6** is shown new concept in various 3D views and terms of use which is based on the design style naturalism. The 3D solid model of plastic bottle

was created in parametric 3D CAD Rhino ceros 5 software. Into design are incorporated the social, economic and technological factors (3D Systems, 2015, M. Saaksjarvi, (2013).

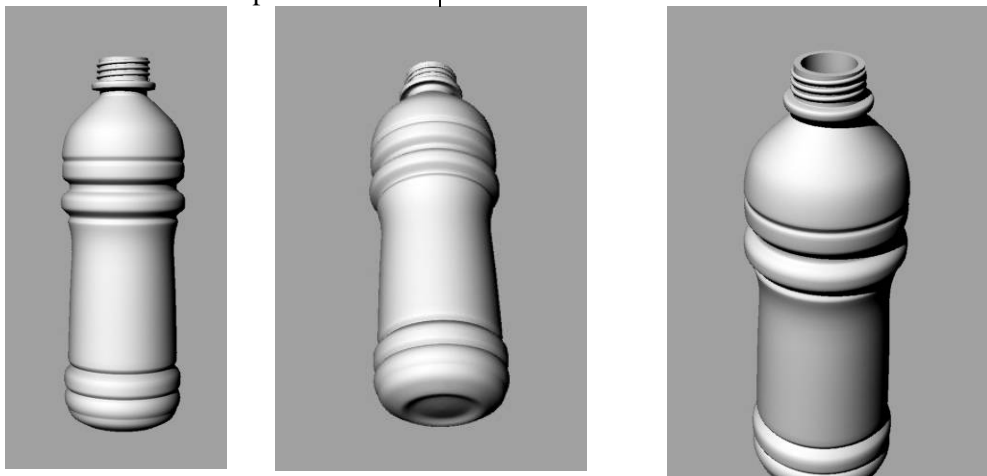

Figure 6: Model of bottle design

3.2. Mold design

The mold was designed using rhinoceros 5

software. It consists of two parts (halves) shown in **Figure 7**. This mold is used for manufacturing the

axi-symmetrical bottle. Mold with the geometrical shape corresponding to some problems occurring

during this process.

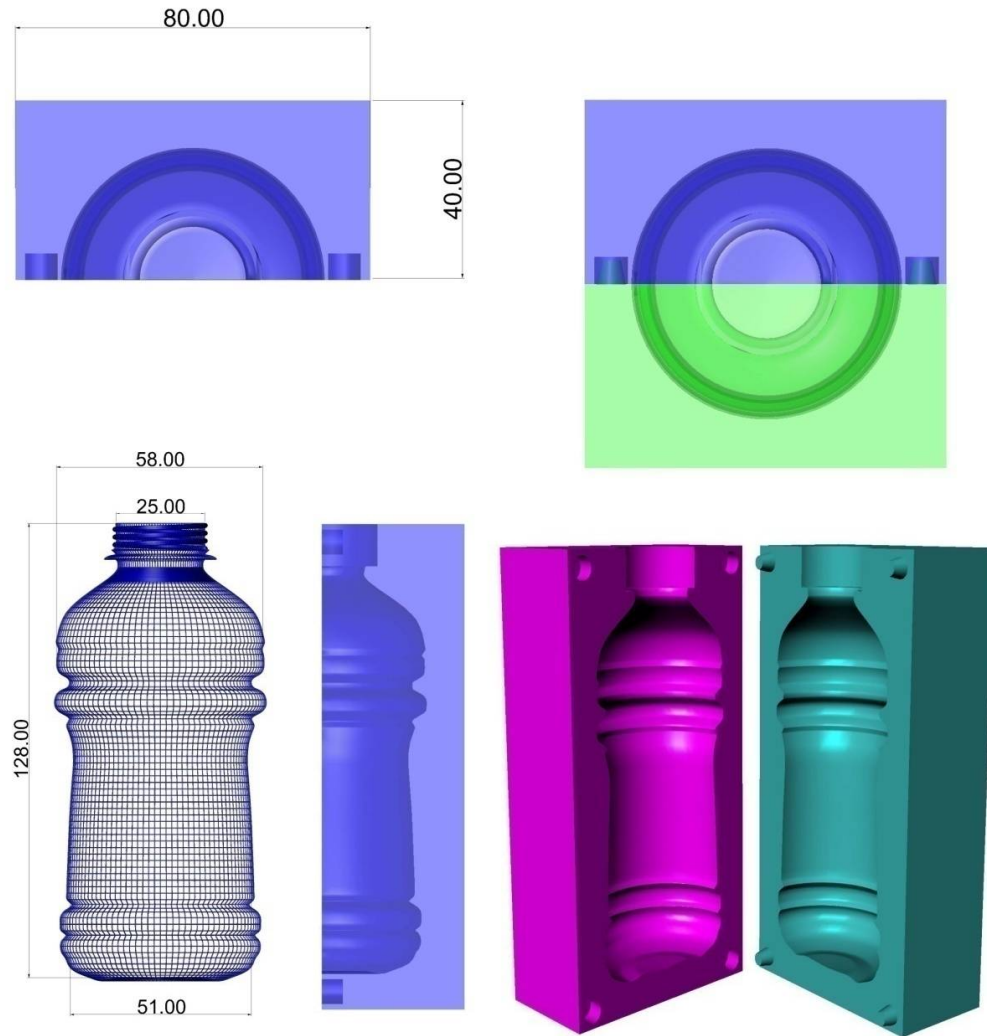

Figure 7: The shape and main dimensions of the Blowing mold

4. Manufacturing Process

4.1. Design Slicing

A sliced model of the mold was made by print-rite

colido Repetier-Host software, as shown in Figure 8.

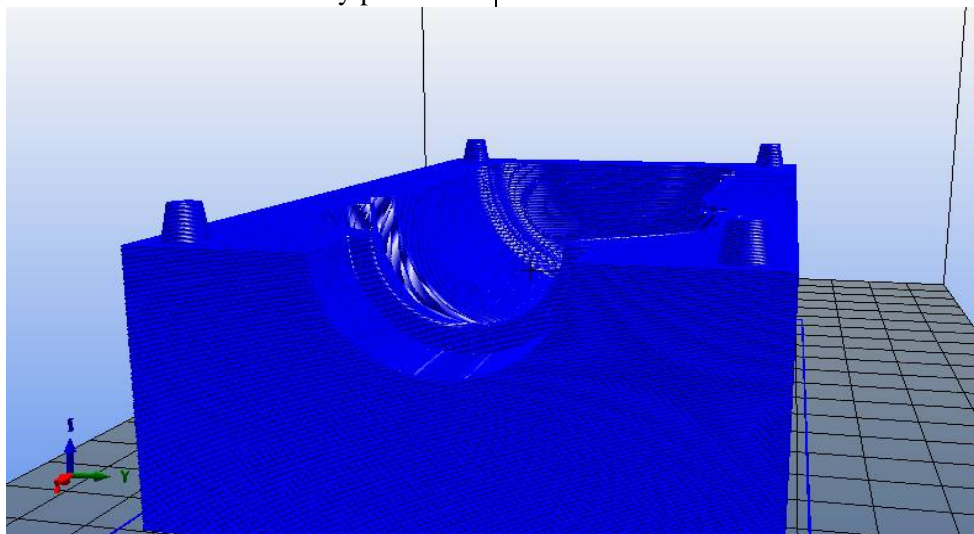

Figure 8: mold design slicing

4.2. Printing settings setup

For the mold printing a default setup of slicing parameters and settings were used. The **Table 1**

below shows the most essential slicing settings. All other settings, **Figure 9**.

Table 1: Printing setting

Printer	colido
Nozzle size(mm):	0.4
Layer height (mm)	0.3
Layer width(mm):	0.48
Infill (%)	20
Perimeters (nr)	3
Top/bottom layers	3
Printing speed (mm/sec)	40
Extruder temperature (°C)	210
Bed temperature (°C)	60
Nozzle fan (on/off)	on

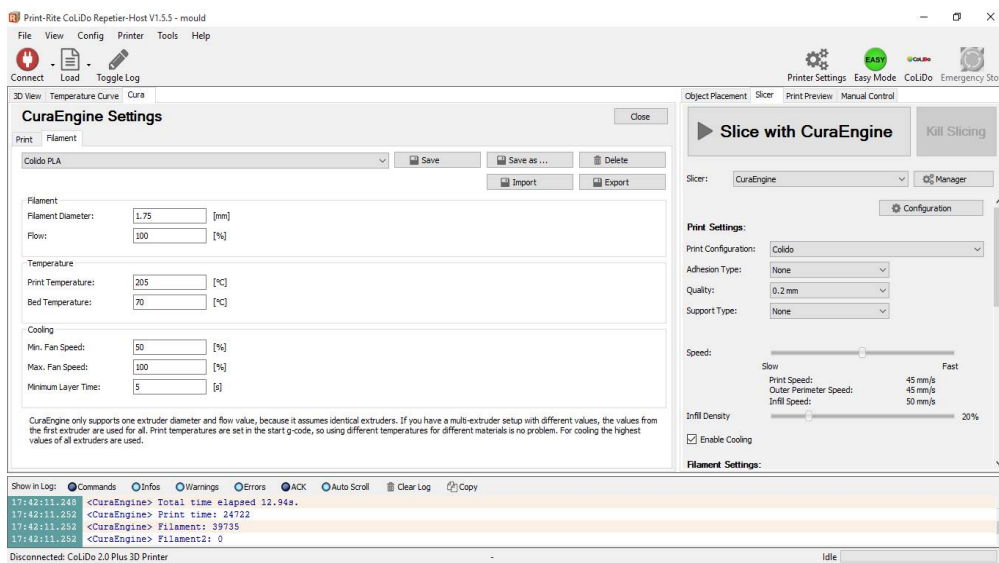

Figure 9: Printing settings setup parameters

4.3. Mold printing

Bottle blowing mold produced using Fused Deposition Modeling (FDM) 3D printing machine colido from (PLA) material filament. Printing accounts time and filament needed shown as **Table 2**. The length and width of the mold were limited by the dimensions of the 3D printer platform shown as **Figure 10**. 3D printers create models layer by layer and the layers' marks can be

seen on a model surface and there is a risk that they will be also visible on the product made in the blowing mold process.

Table 2: Printing Accounts

Printing time	5h:52m:45s
Layer count	227 layer
Total line	264830
Filament	39452 mm

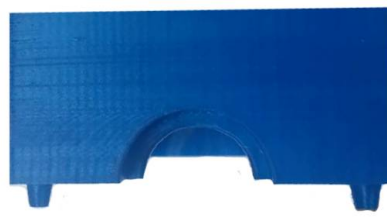
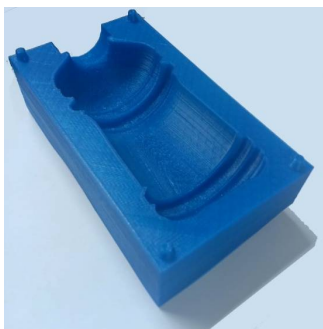

Figure 10:Printed blowing mold



Advancements in AM technology have allowed for the development of blowing mold tools. These tools can create parts with comparable properties to those made on traditional method, yet at lower cost and lead time.

Conclusion

This present work was dealing with study the different prototype blowing mold has been obtained via using FDM using PLA as additive manufacturing plastic material. This mold has shown successfully validated for short productions time as well as reducing mold cost effective. This kind of mold can be considered as well work for bottle product with a good quality as well as can be obtained during the short time of mold making.

References

- [1] K.Stoeckhert, G.Menning(1998), *Mold-Making Handbook*, Hanser Publishers, Munich.
- [2] M. Gierak (1998), Technologiczność konstrukcji opakowań rozdmuchiwanych In: *Formowanie wyrobów z tworzyw sztucznych metodą rozdmuchiwania*. Plastech, pp. 71-105(in Polish).
- [3] Campbell, R.I., Bourell, D. and Gibson, I., (2012). Additive manufacturing: rapid prototyping comes of age. *Rapid Prototyping Journal*, 18 (4), pp. 255 - 258.
- [4] E. Alfredo Campo (2006), *The Complete Part Design Handbook*, Munich, Germany: Hanser, pgs 545-570,
- [5] Dalgarno, K.W. and Stewart , T.D. (2001) Manufacture of production injection mould tooling incorporating conformal cooling channels via indirect selective laser sintering, *Journal Proceedings of the Institution of Mechanical Engineers, Part B: Journal of Engineering Manufacture*, 215(10), pp 1323-1332.
- [6] Ferreira, J.C. and Mateusb, A. (2003) Studies of rapid soft tooling with conformal cooling channels for plastic injection moulding, *Journal of Materials Processing Technology*, 142(2), pp 508-516.
- [7] Norwood, A.J., Dickens, P.M., Soar, R.C., Harris, R., Gibbons, G. and Hansell, R. (2004) Analysis of cooling channels performance, *International Journal of Computer Integrated Manufacturing*, 17(8), pp 669-678.
- [8] Formlabs(2016), *Injection Molding from 3D Printed Molds: A Study of Low-Volume Production of Small Plastic Parts*
- [9] Stratasy(2016) , *Customer Plastic Injection Molding*
- [10] 3D Systems(2015), *Making the Impossible Possible*.
- [11] M. Saaksjarvi (2013), K. Hellen, How designers and marketers can work together to support consumers' happiness, *Int. J. of Design*, 7(3) 33-44.