

2022

## CFD Comparative study of Design and Performance of shell-and-tube Heat Exchangers with different configurations

Heba Abdelhamid

Follow this and additional works at: <https://digitalcommons.aaru.edu.jo/erjeng>

---

### Recommended Citation

Abdelhamid, Heba (2022) "CFD Comparative study of Design and Performance of shell-and-tube Heat Exchangers with different configurations," *Journal of Engineering Research*: Vol. 6: Iss. 3, Article 33. Available at: <https://digitalcommons.aaru.edu.jo/erjeng/vol6/iss3/33>

This Article is brought to you for free and open access by Arab Journals Platform. It has been accepted for inclusion in Journal of Engineering Research by an authorized editor. The journal is hosted on [Digital Commons](#), an Elsevier platform. For more information, please contact [rakan@aar.edu.jo](mailto:rakan@aar.edu.jo), [marah@aar.edu.jo](mailto:marah@aar.edu.jo), [u.murad@aar.edu.jo](mailto:u.murad@aar.edu.jo).

# CFD Comparative Study of Design and Performance of Shell-and-tube Heat Exchangers with Different Configurations

Heba Roushdy Mohamed Abdelhamid, Ayman Ibrahim Bakry, Hagar Alm EIDin Mohamad  
 Department of Mechanical Engineering Departments, Faculty of Engineering, Tanta University, Tanta, Egypt  
 Emails: [heba147824@f-eng.tanta.edu.eg](mailto:heba147824@f-eng.tanta.edu.eg) , [hagaralmeldin@f-eng.tanta.edu.eg](mailto:hagaralmeldin@f-eng.tanta.edu.eg)

**Abstract-** A different models of Shell-and-tube heat exchangers were designed by Ansys geometry & Solidworks to evaluate the best model for heat transfer and to calculate the difference in heat transfer in each model by investigated with numerically modeling. Each model for heat exchanger has different assumptions for first model one tube & one pass with tube length 3 meter, was made with 2 different cases (each case have the same conditions such as same temperature, same velocity, changing the direction of the flow between parallel and counter flow). The flow and temperature fields inside the shell and tubes are resolved using a Ansys CFD 17.2. A set of CFD simulations is performed for a single shell and tube bundle and is compared with the experimental results. the Realizable K- $\epsilon$  model is known for predicting the flow separation better than Standard K- $\epsilon$ . The temperature of each model is examined in detail. Each design was studied separately on the basis of the findings, the designs need modifications to improve heat transfer. The main goal of designing these models is to obtain highest performance for shell and tube heat exchanger with given conditions. These studies were carried out to find the most suitable conditions of operation in shell and tube heat exchanger so that in the future it can improve the performance of heat exchanger in industries through applying these conditions. For future researches, the shell and tube heat exchanger the best case in performance will be chosen, then try to develop the shell and tube heat exchanger and reach maximum performance and efficiency of shell and tube heat exchanger. so that, in industries, the heat exchanger will be easier to be chosen based on the function and conditions required.

**Keywords-** Heat Exchanger; Shell and tube heat Exchanger; Parallel flow; Counter flow; Single pass shell and tube.

## I. INTRODUCTION

Heat exchangers are one of the mostly used equipment in the process industries. Heat exchangers are used to heat transfer between two process streams. One can realize their usage that any process which involves cooling, heating, condensation, boiling or evaporation will require a Heat exchanger for these purposes[1]. Process fluids, usually are heated/cooled before the phase change process is conducted. Different Heat exchangers are named according to their applications. For example, heat exchangers being used to condense are known as condensers, similarly heat exchangers for boiling purposes are called boilers. Performance and efficiency of heat exchangers are measured through the amount of heat transfer using least area of heat transfer and pressure drop. A better presentation of its efficiency is done by calculating over all heat transfer coefficient [1, 2].

In this paper will be discussed and study shell and tube heat exchangers, shell and tube heat exchangers usually provide long service life with little or no maintenance because they have no moving parts. However, there are several types

of mechanical failures that can occur. So, in this study will choose the best operating conditions that gives better performance of shell and tube heat exchanger, so that, in shell and tube heat exchangers can prevent the failures and provide highest efficiency.

Shell and tube heat exchangers are widely popular in petrochemical and energy industries due to their simplicity in design/manufacture and also the capability of adapting to different operating conditions.[3]

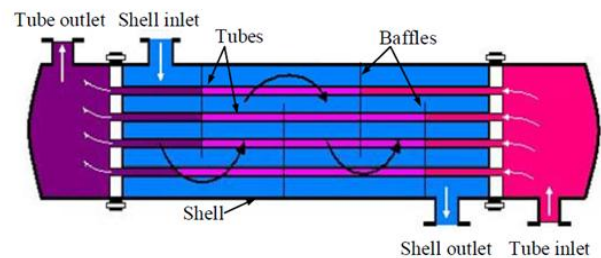

Figure 1. A shell-and-tube heat exchanger with one shell pass and one tube pass (cross and counter flow operation)

As shown in Figure 1, one of the fluids flows inside the tubes while other fluid is forced through the shell and over the outside surfaces of the tubes. To ensure a better circulation of the hot fluid which entered the shell side, the baffles has been placed inside the shell hence they help to induce a high rate of heat transfer[4]. Moreover, the baffles with different shapes/arrangements/spacing are used in the practical applications.

In this work, an investigation was made to show the different types of heat exchangers, to show the flow inside different configuration of shell and tube heat exchangers and how to improve the performance of a shell and tube heat exchangers[5]. The study was occurred for four main aims:

- Selecting single pass of heat exchanger model introducing the fluid flow/flows inside a shell and tube heat exchangers.
- Selecting Double pass of heat exchanger model without baffles introducing the fluid flow/flows inside a shell and tube heat exchangers.
- Selecting Double pass of heat exchanger model with baffles introducing the fluid flow/flows inside a shell and tube heat exchangers.
- Comparing the performance (e.g., heat transfer rate, pressure drop, fabrication cost) of a shell and tube heat exchangers with single pass, double pass, with baffles and without baffles.

This work focuses on the comparison and evaluation between two cases of a shell and tube heat exchangers models with same level of complexity and with the purpose of process

simulation and control design. In both areas, not only reliable and accurate but also fast heat exchanger models are required. The simulation results from these models have been compared against experimental data from a shell and tube heat exchanger.

## II. LITERATURE REVIEW

A heat exchanger is a device used to heat transfer between at least two fluids from high temperatures to low temperatures fluid, or between different surfaces such as solid and fluid or between particulates of solid and fluid, at variety of temperature. In heat exchanger, there are usually no outer heat and work involved in the process. In single or multi component fluid streams there's condensation or evaporations occurs in popular applications which contains heating or cooling [6].

There are two types of heat exchanger which are Indirect heat exchanger and in indirect contact heat exchanger is used in some applications not as popular as direct heat exchanger. In Direct contact heat exchanger is popular because of the using the heat transfer between fluids occurs through a wall that disconnect fluids from each other or in & out of the wall in a transient way[7].

The fluids are divides by a surface wall. In ideal way heat transfer are perfectly don't blend or infiltration. In conclusion, Classifications of heat exchanger due to transfer process. In Ind transfer type or regenerator, the heat exchangers mutually allow low temperature and cold temperature fluids to flow through the same channel. In such heat exchanger always have leakage from hot fluid to cold fluid or vice versa due to pressure difference and other factors. Application of indirect heat exchanger (regenerator) are condensers, Preheaters, cooling towers, radiators and .....etc. In sensible heat exchanger there's no phase change take place inside heat exchanger in any of the fluids[8].

In some applications such as fire heaters, boilers and fluidized bed combustion and chemical reaction occurs within the heat exchanger. The most popular heat exchanger is shell and tube heat exchangers. Shell and tube heat exchangers is most effective type of heat exchanger. Shell and tube heat exchangers consist of cylindrical shell and bunch of tubes which called bundle of tubes. The materials of tubes are made from material that makes Heat transfer among cold fluid flowing inside the tubes and hot fluid flowing outside the tubes through the shell which called conductive materials[9].

In figure 2, the shell and tube heat exchangers consist of tubes mounted in shell that cylindrical shape which are parallel flow along cold fluid that flows inside tubes and the hot fluid that flows across the shell. The main components of this heat exchangers are tubes, shell, baffles, tubes, sheets, rear end head and fronted end head[10].

Decreasing thermal stresses in shell-and-tube heat exchangers for easier cleaning, stopping leakage, decrease corrosion, containing temperature & temperature and .....etc. A different internal construction has been made count on heat transfer and pressure drop showing. The selection of shell and tube heat exchanger are based on TEMA (Tubular Exchanger Manufactures Association) and other standards such as ASME (American Society of Mechanical Engineers).

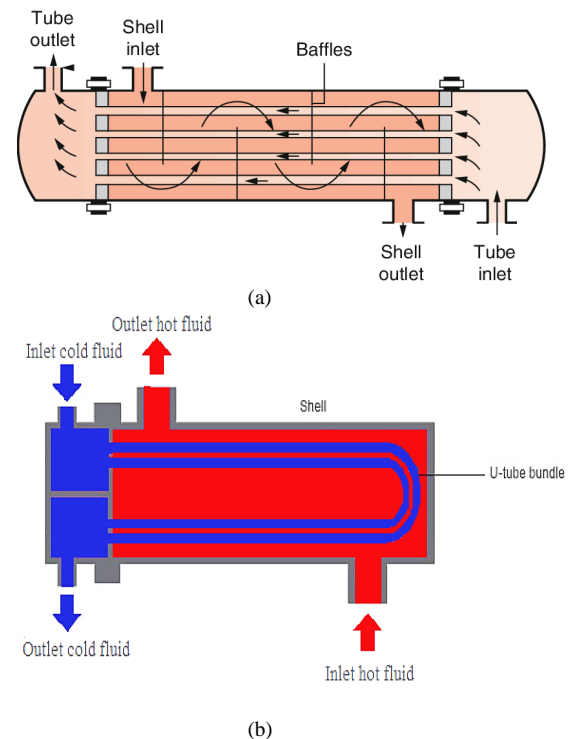

Figure 2. (a) A shell and tube heat exchanger, one shell pass and one tube pass; (b) Shell and tube exchanger with two tube passes

TEMA has created regulation for the most important types of shell and tube heat exchanger. In this regulation the heat exchanger consists of shell and tube heat exchangers in this regulation, the heat exchanger consists of 3 components. First components the front-end head type, the second is the rear end head type and the third is the shell type.[11]

## III. EXPERIMENTAL METHODOLOGY DESCRIPTION

Heat exchanger is a device that its main function is to transfer energy between fluids at different temperatures through heat transfer. They are classified according to construction is being used and that classification separates heat exchangers in recuperators and regenerators. Firstly, let's discuss recuperators, heat transfer in recuperators directly between the two fluids and by opposition. However, in regenerators, there is no immediate heat transfer between the fluids[12].

The definition of design is an activity aimed at providing a description of part, single, a whole engineering system component. Such descriptions represent a clear specification of the system structure such as size, performance and other characteristics that are necessary for subsequent manufacturing and utilization.[13]

A well-defined design methodology can accomplish the above goals. We should hint out that the design methodology for such scope has a very complex structure. Therefore, a design methodology for a heat exchanger shall be consistent with the life-cycle design of the system.

The following steps are of life-cycle design that assumes considerations organized:

- Problem formulation (interaction with a consumer is included)
- Concept development (selection of workable designs, preliminary designs)

- Detailed heat exchanger design (design calculations and other relevant considerations)
- Manufacturing
- Utilization considerations (operation, phase-out, disposal)

All considerations must be taken into account. The problems occurs within the heat exchanger is linked to startups, temporary, unorganized, steady operations, transient and ultimately, the retirement, should be considered as well. If any constraints are imposed, iteration of one or more steps till all the requirements are met within the tolerable limits as a reconsideration of the conclusion must be taken into account. A particular design methodology has to be developed within the framework of these activities[14].

The methodology behind designing a new single heat exchanger is based on experience and presented by Kays and London in 1998, Taborek in 1988, and Shah in 1982 for compact and shell and tube heat exchangers. The design procedure to be mentioned can be characterized as a case study method. Major design considerations include[15]:

- Process and design specifications.
- Thermal and hydraulic design
- Mechanical design
- Manufacturing considerations and cost
- Trade-off factors and system-based optimization

An engineer must specify requirements and define main goal of a system design as an initial stage based on the good understanding of customer needs. After the problem is clearly formulated, the engineer evaluates alternative concepts of the system design and then selects one or more workable design solutions. A detailed sizing, costing and optimization have to be completed based on the analysis performed. Such activity leads to proposed design solution.

Recuperators can be classified according to transfer process in direct contact with indirect contact types. In the indirect heat exchanger, a physical separation (wall) between the fluids exists. The recuperators are referred to as direct transfer type.

The regenerators, however, are devices in which there is an intermittent heat exchanger between the hot and cold fluids through thermal energy storage and release through the heat exchanger surface or matrix. Regenerators are classified into rotary and fixed matrix models. Regenerators are referred to as an indirect transfer type[16].

The basic design methods for two fluid heat exchangers are:

- 1) Logarithmic mean temperature difference method (LMTD)
- 2) effectiveness-number of transfer units ( $\epsilon - NTU$ )
- 3) dimensionless mean temperature difference ( $\Psi - P$ ) and ( $P_1 - P_2$ ) effectiveness-modified number of transfer units ( $\epsilon - NTU_o$ )
- 4) reduced length and reduced period ( $\Lambda - \pi$ )

Heat exchangers are usually analyzed using either the Logarithmic Mean Temperature Difference (LMTD) or the Effectiveness – Number of Transfer Units ( $\epsilon - NTU$ ) methods. The LMTD method is convenient for determining the overall heat transfer coefficient based on the measured inlet and outlet fluid temperatures. When heat transfer coefficient is known for the inlet temperature, then it's easily to predict outlet fluid temperatures, for that method is the most proper.

The analysis presented below assumes that

1. No energy loss occurs within heat exchanger to the surroundings.
2. Heat exchanger is at a steady-state.
3. The fluid has no phase change occurs during the operation
4. The fluid heat capacity isn't dependent of temperature
5. Total heat transfer coefficient is independent of the position of the fluid temperature of the fluid within the heat exchanger.

So that, it's known transfer units has effectiveness modified no. which refer to ( $\epsilon - NTU_o$ ) decrease period and length ( $\Lambda - \pi$ ) methods for heat exchanger (regenerators). ( $\Psi - P$ ) and ( $p_1-p_2$ ) method are considered to be graphical methods. ( $p_1-p_2$ ) The method contains all the main parameters that dimensionless in heat exchanger. Therefore, the results to sizing and rating problem isn't repeated straight forward. The objective of this project is to design a shell and tube heat exchanger and to study the flow and temperatures inside the shell and tube heat exchangers using ANSYS software tool to calculate overall heat transfer is for each case. The process in solving simulation consists of modeling and meshing the basic geometry of shell and tube heat exchanger using CFD package ANSYS 17.2.

The most commonly used correlation in shell and tube heat exchanger design are Ken method and bell-Delaware because the design of shell and tube heat exchanger is normally based on correlations. For preliminary design and provides conservative results ken method is the mostly used method. However, for more accurate method and can provide detailed results bell-Delaware method is better option for it. Also for better accuracy because bell-Delaware can predict and determine pressure drop and heat transfer coefficient.

The Bell-Delaware is the rating method which can predict the weakness in the shell side. However, it can't locate these weaknesses are. So that to find out the weaknesses, flow distribution must be estimate. Many studies such as numerical, analytical and experimental studies have been carried out, for this particularly reason. Most of this research was focused on the particular aspects of the shell and tube heat exchanger design[17].

Regularly, pressure drop and heat transfer in heat exchanger has been done a lot of work on them. So that it can be summarized to three parts for pressure drop in heat exchanger. Fundamentally the pressure drop happen because of fanning friction over the pipe. Also happen due to changes in the flow geometry such as expansion and contraction of the beginning and end of heat exchanger.

Pressure drop losses correlations provided by handbook of hydraulic resistance for these regions separately. It happens through in introducing coefficients of pressure loss. To calculate the loss in both entrance and exit by equations 1 and 2 respectively.

$$\Delta P_{en} = (1 - \sigma_e^2 + K_c)G^2/2\rho \text{-----}(1)$$

$$\Delta P_{ex} = (1 - \sigma_e^2 + K_e)G^2/2\rho \text{-----}(2)$$

Where,

$K_c$ =Entrance pressure drop efficient

$K_e$ = Exit pressure drop efficient

$\sigma$ = Minimum flow area/ frontal area= $\frac{A_1}{A_2}$

$G$ =Mass velocity ( $Kg/m^2s$ )

By using Darcy- Weisbach equations, to start the study with heat exchanger unbaffled, so that it makes it comparable to straight annular pipe that leads to hydraulic diameter can be calculated of shell side for both entrance and exit of pressure drop.

$$\Delta P = f \frac{L\rho v^2}{2D} \text{-----} (3)$$

Where,

$\Delta P$ =Pressure Drop (Pa)

$f$  =Fanning friction factor

$L$ = Length of pipe (m)

$P$ = Fluid density (kg/m<sup>3</sup>)

$D$ =Hydraulic diameter of pipe (m)

Likewise, an annular pipe heat transfer coefficient can also be calculated. CFD model has been made to validate three-dimensional tube in tube heat exchanger by Meyer et al. This model used for comparison heat transfer coefficient with CFD results. In equation 4 correlation of Dittus-Boelter provides Nusselt number by help of both Prandtl number & Reynolds number.

$$Nu_u = 0.023Re^{0.8}Pr^n \text{-----} (4)$$

CFD use in design of heat exchanger is limited in comparison with correlation-based method. Iteratively and rating in the sizing of heat exchanger can use CFD in both of them. CFD can be used in initial design steps specifically also can be used with reducing number prototype testing and with transport phenomena happening in heat exchangers which can gives good insight of it.

For very specified heat exchanger model to be run successfully with full CFD simulation requires a long computation time, large computer memory and large amount of computing to run industrial shell and tube heat exchanger without any simplification for example shell and tube heat exchanger with 60 tubes and 12 baffles, would require at least 160 million computational elements for geometry solution.

So that with normal computer, it's impossible to model this geometry. For that reason, heat exchangers can be modeled by using some simplifications to solve that problem.

Generally, simplifications are used for the porous medium model and distributed resistance approach. Distributed resistance approach can be used to modeled shell and tube heat exchangers. A single computational cell may have multiple tubes when using distributed resistance approach method.

Subsequently, heat exchanger shell can be modeled by coarse grid relatively. Multi-dimensional and thermal hydraulic model has been developed by Kao et al. In which shell side was modeled by using volumetric porosity, distributed resistance methods and surface porosity. In most of these simplified approaches, the shell side pressure drop and heat transfer results display good agreement with experimental data[18].

Because of the simplification approaches, it can predict heat transfer coefficient and pressure drop of shell side effectively, despite that to conception of shell side flow and temperature fields in details, a full CFD model is needed for shell side. With increasing capabilities of computational, the cells number is increasing that can be used in CFD model[19].

By using normal computers and software, it's possible to model an industrial scale shell and tube heat exchanger in

details, by design geometry as precisely as possible, the flow structure and the temperature distribution inside shell can be achieved.

These specified data can be used for estimating global parameters like heat transfer coefficient and pressure drop that be in comparison with correlation based or experimental ones. Furthermore, the data can also be used to show the flow and temperature fields and that would help in estimating the location if the weaknesses in the design for example: recirculation and re-laminarization zones[20].

Both software of commercial and non-commercial have been used to model different types of heat exchangers. Usually, two equation models have been used for modeling the flow. k-ε models are the most popular model to use in industrial designs over with wall functions. Jae et al has made a comparison for different near wall treatment method for high Reynolds number flows. The non-equilibrium wall functions over with k-ε models have been found that they accurately predict reattachment lengths. However, two layers model represent total flow domain way better. This near wall treatment is dependently using much upon the choice of turbulence model.

The main and basic process for all process industries is heat transfer. Through heat transfer process, high temperature fluid transfer its energy in form of heat to the low temperature fluid. There are three mechanisms that fluid can transfer its energy with which are conduction, radiation and convection. Radiation isn't popular mechanism of heat transfer in process industries but it's popular in other processes.

Radiation has important role in heat transfer such as in combustion furnace. The conduction and convection the other two modes of heat transfer are more important in process industries[20].

The overall energy balance for heat transfer system can be calculated by equations 5 & 6:

$$Q_h = m_h C_p (T_{h,i} - T_{h,o}) \text{-----} (5)$$

$$Q_c = m_c C_p (T_{c,i} - T_{c,o}) \text{-----} (6)$$

Because of losses and resistance in the form of wall fouling, the amount of heat transfer by high temperature fluid to the low temperature fluid is not the same. For that mount heat assumption has been made from high temperature fluid is equal to the amount of heat transferred to low temperature fluid. Normally, environmental losses have been minimized by making heat exchangers isolated [21].

It can be written by the following:

$$Q_h = Q_c = Q \text{-----} (7)$$

The T-Q diagram is represented by these equations to make the process simpler and easier to understand. To prove that 2nd law of thermodynamic is achieved by using these graphs[22]. I.e. the heat always has to be heat transferred from high temperature to low temperature fluid.

Fundamentals of heat transfer along surface is given by:

$$Q = UA\Delta T_{lm} = wC_{p(t)}(t_2 - t_1) = wC_{p(s)}(t_1 - t_2) \text{ or } WL \text{ (8)}$$

where,

$Q$ =heat transferred per unit time (KJ/h, Btu/h)

$U$ = the overall heat transfer coefficient (KJ/h-m<sup>2</sup>°C, Btu/h-ft<sup>2</sup>-°F)

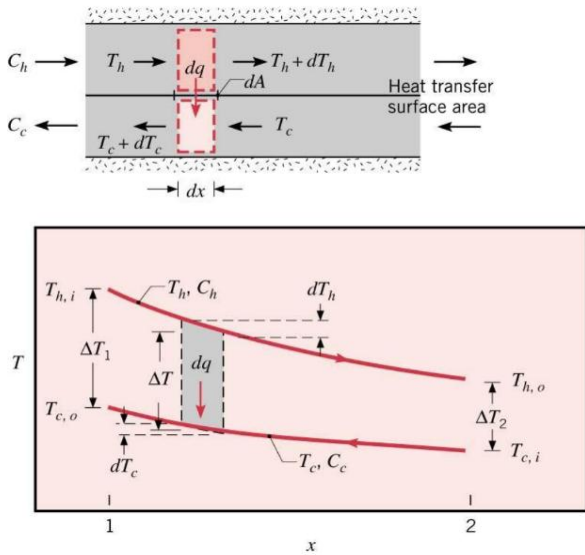

Figure 3: Heat Transfer surface area in a Heat Exchanger [12]

A=heat-transfer area (m<sup>2</sup>,ft<sup>2</sup>)  
 $\Delta T_{lm}$ =log mean temperature difference(°C, °F)  
 $C_{p(t)}$ =liquid specific heat tube side.  
 $C_{p(s)}$ =liquid specific heat shell side(KJ/Kg-°K,Btu/lb-°F)  
 w=tube side flow W shell side flow(Kg/h, lb/h)  
 The log mean temperature difference (LMTD) for countercurrent flow is given by:

$$\Delta T_{lm} = \frac{(T_1 - t_2) - (T_2 - t_1)}{\ln \frac{(T_1 - t_2)}{(T_2 - t_1)}} \quad \text{-----(9)}$$

where,  
 $T_1$ =inlet temperature for shell side fluid.  
 $T_2$ = outlet temperature for shell side fluid.  
 $t_1$ =inlet temperature for tube side.  
 $t_2$ = outlet temperature for tube side.

The correction factors can be considered as a function of number of tube passes, number of shell passes [23], fluid temperature and is correlated as function of two dimensionless temperature ratios:

$$R = \frac{(T_1 - T_2)}{(t_2 - t_1)} \quad \text{----- (10)}$$

$$S = \frac{(t_2 - t_1)}{(T_1 - t_1)} \quad \text{----- (11)}$$

The overall heat transfer coefficient has been calculated based on the outside surface area of the wall for the unfinned tubular heat exchangers,

$$U_o = \frac{1}{\frac{r_o}{r_i} \frac{1}{h_i} + R_{fi} + \frac{r_o}{k} \ln \left( \frac{r_o}{r_i} \right) + R_{fo} + \frac{1}{h_o}} \quad \text{---- (12)}$$

where  $R_{fi}$  and  $R_{fo}$  are fouling resistance of the inside and outside surfaces, respectively.

Or

$$U_o = \frac{1}{\frac{r_o}{r_i} \frac{1}{h_i} + R_{ft} + \frac{r_o}{k} \ln \left( \frac{r_o}{r_i} \right) + \frac{1}{h_o}} \quad \text{----- (12)}$$

where  $R_{ft}$  is the total fouling resistance for finned surfaces., given as:

$$R_{ft} = \frac{A_o}{A_i} R_{fi} + R_{fo} \quad \text{----- (13)}$$

The overall heat transfer coefficient is established on the outside surface area of the wall for the finned tubular Heat exchangers,

$$U_o = \frac{1}{\frac{A_o}{A_i} \frac{1}{n_i h_i} + \frac{A_o}{A_i} R_{fi} + A_o R_w + \frac{R_{fo}}{n_o} + \frac{1}{n_o h_o}} \quad \text{---- (14)}$$

where,

$R_{fi}$  &  $R_{fo}$ = fouling resistance of the inside and outside surfaces.

$R_{ft}$ = The total fouling resistance.

$A_f$ = fin surface area

$n_f$ = fin efficiency

$L$ = fin length

$L_c$ = corrected fin length

$D$ = the diameter of the cylindrical fins

$A_o$  and  $A_i$ = the total surface area of the outer and inner surfaces

$$\frac{dE_{cv}}{dt} = Q - W + \sum_i m_i \left( h_i + \frac{v_i^2}{2} + gz_i \right) - \sum_e m_e \left( h_e + \frac{v_e^2}{2} + gz_e \right) \quad \text{.....(15)}$$

$Q$ = Heat transfer rate, Kw

$M$ = Mass flow rate Kg/s

$E$ = Total Energy, KJ

$H$ = Specific enthalpy, KJ/Kg

$C$ = Flow stream Capacity, W/K

For a control volume at steady state,  $\frac{dE_{cv}}{dt}=0$ . Changes in the potential energy and kinetic energy of the flowing streams from entrance to exit can be neglected. The flow work is the only work of a control volume including a heat exchanger, so  $W=0$  and single-stream (only one inlet and one exit) and from the steady-state form the heat transfer rate turned straightforward.

These equations from 5 to 9 are derived by the help of different assumptions [24]. Mainly, the overall heat transfer coefficient and specific heat capacity are considered constant for the heat exchangers. In real life cases, the fluids' Temperatures and properties can change the values depending on them. It's noticeable that water – which one of many industrial fluids- specific heat capacity remain fixed for range of temperatures. For example:

Specific heat capacity of water at 273.5K and atmospheric pressure = 4218 J/Kg.K

Specific heat capacity of water at 374K and atmospheric pressure= 4226J/kg.K

So that, for these temperatures range this assumption works well. Specific heat of a fluid is the property of fluid by which it transfers heat. It can be said that the amount of heat required by the one kilogram of fluid to increase its temperature by one degree Celsius. The log mean temperature difference (  $LMTD$  ) is calculated to estimate the average temperature difference throughout the heat exchanger. It is basically the logarithmic average of temperature difference[25]. As for a heat transfer the driving force is always the temperature difference, thus higher log mean temperature difference will ensure better heat transfer. It is related to area of heat exchanger in a way that higher  $LMTD$  will cause less heat transfer area and lower  $LMTD$  will need larger heat transfer area. Generally,  $LMTD$  is a process condition and one cannot do much about it as inlet and outlet temperatures of fluids are usually pre decided for a heat

exchanger design. Area can certainly be reduced by making the full use of available *LMTD* by efficient heat transfer[26].

#### A. Overall heat transfer coefficient

The overall heat transfer of heat exchangers is the ability of transferring heat through different resistances, it depends upon, the properties of the process fluids, temperatures, flow rates and geometrical arrangement of the heat exchanger. For example, the number of passes, number of baffles and baffle spacing etc [27]. It is defined by the Equation 16. This equation basically sums up all the resistances encountered during the heat transfer and taking the reciprocal gives us the overall heat transfer coefficient.

$$\frac{1}{U} = \frac{1}{h_h} + \frac{\Delta x}{k} + \frac{1}{h_c} + R_f \text{-----(16)}$$

where:

$h_h$ =Hot side heat transfer coefficient(W/m<sup>2</sup>.k)

$h_c$ =Cold side heat transfer coefficient(W/m<sup>2</sup>.k)

$\Delta x$ =Exchanger tube wall thickness (m)

$k$ =Exchanger wall material thermal conductivity(W/m.K)

$R_f$ =Fouling Coefficient (W/m<sup>2</sup>.K)

The equation for the overall heat transfer coefficient can be written as the equation 17:

$$\frac{1}{U} = \frac{1}{h_h} + \frac{1}{h_c} + R_f \text{----- (17)}$$

$h_h$  and  $h_c$  are the individual film coefficients and are defined as the measure of heat transfer for unit area and unit temperature difference. These are calculated separately for both outside and inside fluids. The temperature difference of average temperature of bulk fluid (hot and cold) and wall temperature [28] (inside and outside) is the driving force for the respective fluids.  $\Delta x / k$  is usually ignored as it doesn't have a significant effect on the overall heat transfer coefficient [29].

The current study covers some of the important factors affecting the performance of shell and tube heat exchangers, and then the analysis of different geometries of shell and tube heat exchangers. It was evident from the analysis that providing orientation to the shell and tube heat exchangers with segmented baffles give better results than shell and tube heat exchangers with no baffles or baffles having 0° orientation angle due to better heat transfer performance, less fouling and less pressure drop. The effectiveness of the heat exchangers with sealers is higher than that of the heat exchanger having no such arrangement.

## IV.COMPUTATIONAL FLUID DYNAMICS

CFD is a sophisticated computationally-based design and analysis technique. CFD software gives you the power to simulate flows of gases and liquids, heat and mass transfer, moving bodies, multiphase physics, chemical reaction, fluid-structure interaction and acoustics through computer modelling. This software can also build a virtual prototype of the system or device before can be apply to real-world physics and chemistry to the model, and the software will provide with images and data, which predict the performance of that design. Computational fluid dynamics (CFD) is useful in a wide

variety of applications and use in industry. CFD is one of the branches of fluid mechanics that uses numerical methods and algorithm can be used to solve and analyze problems that involve fluid flows and also simulate the flow over a piping, vehicle or machinery. Computers are used to perform the millions of calculations required to simulate the interaction of fluids and gases with the complex surfaces used in engineering. More accurate codes that can accurately and quickly simulate even complex scenarios such as supersonic and turbulent flows are ongoing research. Onwards the aerospace industry has integrated CFD techniques into the design, R & D and manufacture of aircraft and jet engines. More recently the methods have been applied to the design of internal combustion engine, combustion chambers of gas turbine and furnaces also fluid flows and heat transfer in heat exchanger.

Computational fluid dynamic study of the system starts with building desired geometry and mesh for modeling the domain. Generally, geometry is simplified for the CFD studies. Meshing is the discretization of the domain into small volumes where the equations are solved by the help of iterative methods. Modeling starts with defining the boundary and initial conditions for the domain and leads to modeling the entire system domain. Finally, it is followed by the analysis of the results.

#### A. Model of shell and tube heat exchanger Creating Geometry

Heat exchanger geometry is built in the ANSYS workbench design module. Geometry is simplified by considering working on one tube with one pass shell and tube heat exchangers. The first model specifications are as table 1

**Table 1. Heat Exchanger Dimensions**

No.	Description	Value
1	Tube ID (m)	1
2	Tube OD (m)	1.1
3	Tube Length (m)	3
4	Shell ID (m)	1.5
5	Shell OD (m)	1.6
6	Shell Length (m)	2.4
7	No. of tubes	1
8	No. of passes	1

This model is based on assumption similar to the experimental conditions in order to have a comparison. In the Figure 1, can find the geometry of shell and tube heat exchanger one tube and one pass. And figure 4.2 can find the direction of cold flow and hot flow in shell and tube heat exchangers for the first case.

#### B. Mesh Generation and Quality

Initially a relatively coarser mesh is generated with 7.2e06 Elements & 1.55e06 nodes with minimum element quality 0.21452, average elements quality 0.83004, Skewness min. 6.2398e-011, average 0.23913 & Standard Deviation 0.12198. This mesh contains mixed cells (Tetra and Hexahedral cells) having both triangular and quadrilateral faces at the boundaries. Care is taken to use structured cells (Hexahedral) as much as possible with inflation size function Proximity and curvature to solve the meshing with as smooth as possible, for this reason the geometry is divided into several parts for using automatic methods available in the ANSYS meshing client.

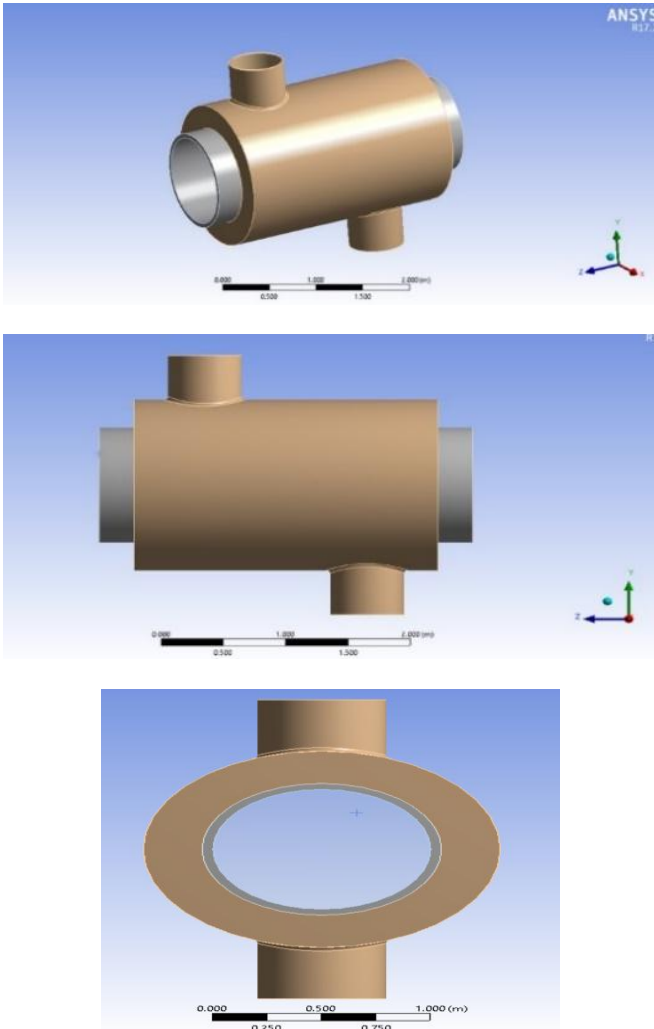

Figure 4. Geometry for shell and tube heat exchanger one tube & one pass

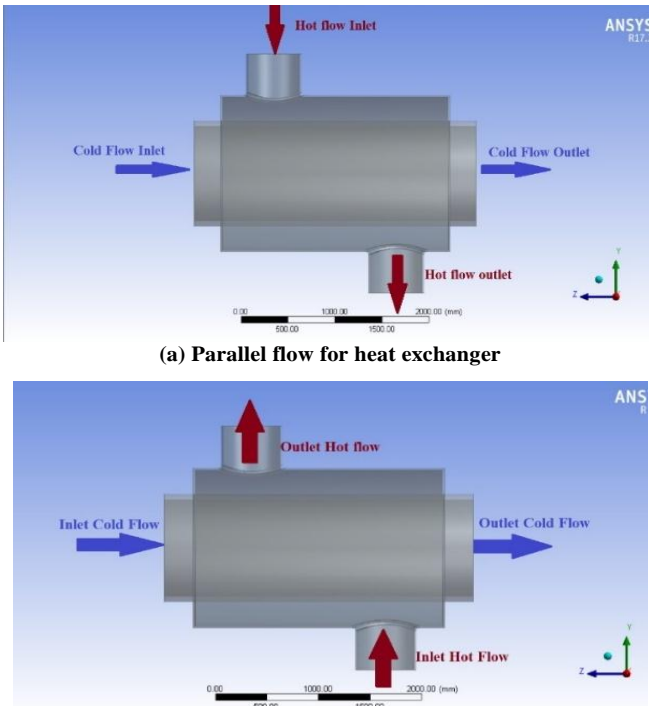

Figure 5. (a&b) Flow Direction for shell and tube heat exchanger one tube & one pass

It is meant to reduce numerical diffusion as much as possible by structuring the mesh in a well manner, particularly near the wall region. Later on, for the mesh independent model, a fine mesh is generated with 6.53e06 Elements & 1.43e06 nodes with minimum Elements quality 0.16586, average Elements quality 0.83029, Skewness min. 2.4167e-011, average 0.23867 & Standard Deviation 0.121838 as can be seen in figure 4.3. For this fine mesh, the edges and regions of high temperature and pressure gradients are finely meshed.

C. Grid Independence test

In the cases of this study, the contours from coarser mesh and fine mesh are analyzed and it is noted that fine mesh resolves the region of high pressure and temperature gradients better as compared to coarse mesh. Thus, taking care of these particular regions, coarse mesh is adapted to resolve these gradients. The criterion for adaption are temperature and pressure gradients. It is mainly refined in inlet and outlet regions to get the better estimations of pressure drop and heat transfer. Rapid mixing of hot and cold fluids is observed at the outlet, which led to refine the mesh further. Adaptions on the basis of temperature and pressure gradients are made to the mesh to get a fully grid independent model. Aspect ratio of the cells is kept same as coarse mesh because it is checked that the aspect ratio doesn't affect much.

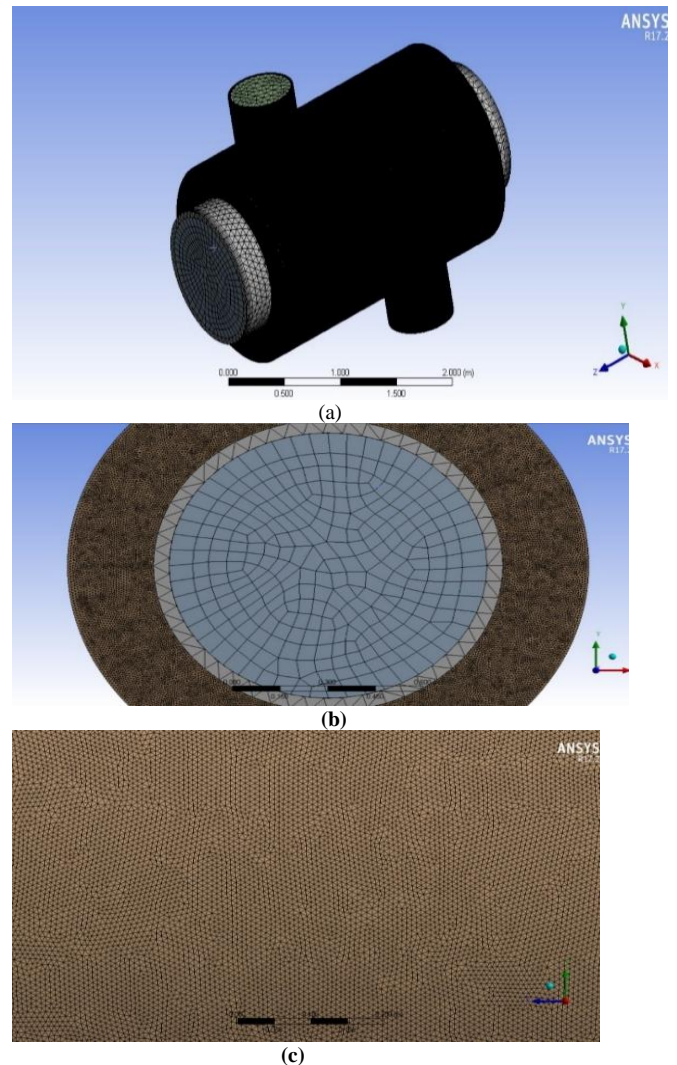

Figure 6. (a),(b)&(c) Different view for fine mesh for shell and tube heat exchanger



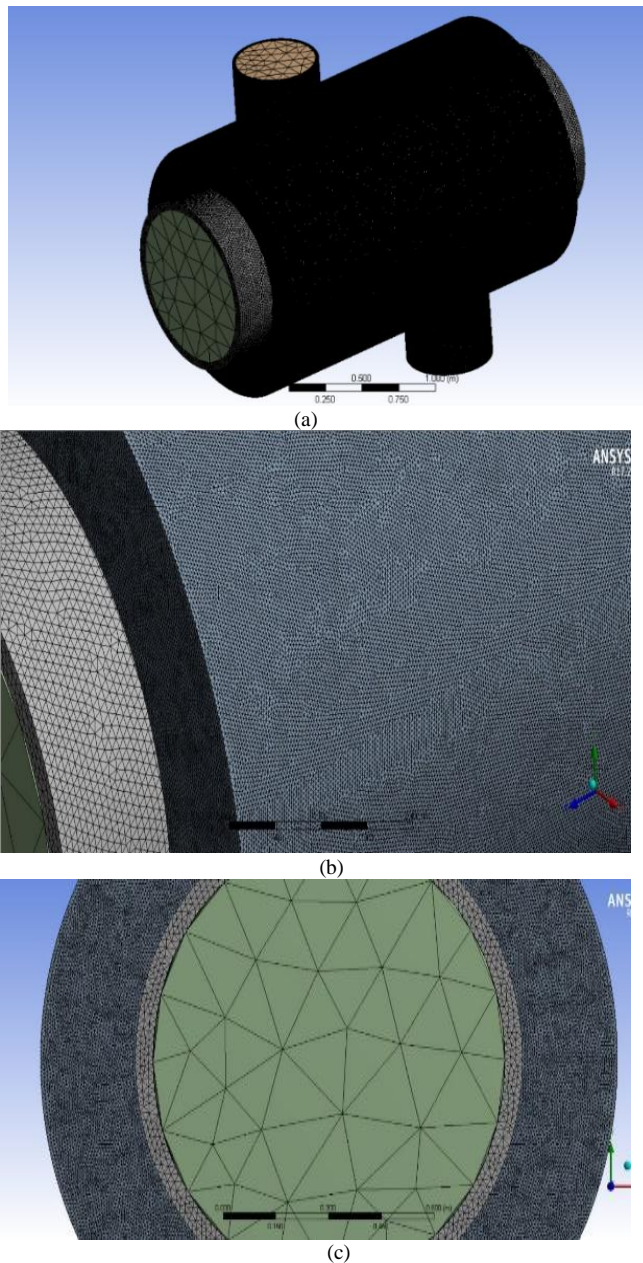

Figure 7. (a),(b) &(c) Different views for Coarse mesh for shell and tube heat exchange

#### D. Pie Chart

In the three cases mentioned previously, the mesh contained different types of cells but 76% of them are hexahedral cells. Detailed composition of the mesh can be seen in the Pie chart Figure 8.

#### E. Discretization Scheme

There are several discretization schemes to choose from. Initially every model is run with the first order upwind scheme and then later changed to the second order upwind scheme. It is done to have better convergence but changed to higher order scheme to avoid the numerical diffusion. It is seen that the flow is unidirectional in most of the domain. So, it is recommended to use second order schemes for strong convection. Second order upwind scheme fulfills the property of transportive and is more accurate than first order scheme. A major drawback

of this scheme is its unboundedness which is not the case with first order scheme.

#### F. Boundary conditions

Boundary conditions are used according to assumptions made to simplify the cases. The inlet velocities and temperature are used similar to the experimental conditions in order to have a comparison. Each case has different number of tubes and passes as shown in following tables from 2:3 similar inlet and outlet boundary conditions.

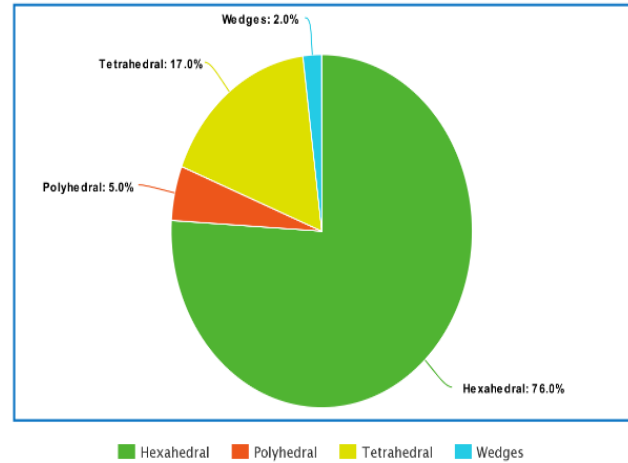

Figure 8. Mesh Composition

Table 2: First Case one pass, one tube parallel flow

	BC type	Shell	Tube
Inlet	Velocity inlet	2 m/sec	1.2 m/sec
Outlet	Pressure outlet	0.0	0.0
Wall	No slip condition	No heat flux	Coupled
Temperature	Inlet Temp	60 °C	16 °C
	Outlet Temp	25 °C	25 °C

Table 3: Second Case one pass, one tube Counter flow

	BC type	Shell	Tube
Inlet	Velocity inlet	2 m/sec	1.2 m/sec
Outlet	Pressure outlet	0.0	0.0
Wall	No slip condition	No heat flux	Coupled
Temperature	Inlet Temp	60 °C	16 °C
	Outlet Temp	25 °C	25 °C

## V. RESULTS AND DISCUSSIONS

The entire CFD process consists of three stages: pre-processing, solving, and post-processing. All three processes are interdependent. As much as 90% of effort is used in the meshing (preprocessing) stage. This requires the user to be dexterous and there must be the idea of creating an understandable topology. The next stage is to solve the governing equations of flow, which is the computer's work. Remember that an error embedded in the mesh will propagate in the solving stage as well, and if you are lucky enough, you may get a converged solution. However, mostly, owing to only one culprit cell, the solution diverges. The next phase after solving equations is post-processing. There, the results of whatever was input and solved are obtained; colorful pictures showing contours are interpreted for product design, development, or optimization. For validation, the results are compared with experimental data. If any experimental data are absent, the grid convergence study better judges the

authenticity of the results. CFD helps us in many complicated cases for which we cannot easily judge or analyze based on experimental or analytical data. The growing popularity of CFD is solely due to the rapid increase in computational power and the efficacy that is reflected by the field itself. However, because humanity's desires do not rest, as computational power crosses a quadrillion floating-point operations per second, scientists and fluid dynamitists will begin to float new complex problems that are currently thought to be impossible to solve.

The CFD simulation is carried out for models. Firstly, the model of one tube and one pass, starting with parallel flow with Standard model is used at first to get a picture of the flow distribution but it is not good for predicting the boundary layer separation and impinging flows. Thus, results are expected to be deviating from experimental results. Whereas, the Realizable model is known for predicting the flow separation better than Standard. For this reason, Realizable, model is used with standard and then non-equilibrium wall functions.

Non-equilibrium wall functions are better than standard wall functions because of their applicability in the regions of variable shear and departure from equilibrium. Then changing the geometry to counter flow with changing the temperature and velocities of the fluids, and start solution with Standard k- $\epsilon$  model then the same steps as previous. The last case in this model choosing parallel flow with double velocities of the first case and changing the temperature as mentioned in tables previously. then started the same steps as previous two cases in solution. These wall functions also take into account the effect of high-pressure gradient. The standard wall functions are over predicting the pressure drop and heat transfer as well. Whereas, the non-equilibrium wall functions with Realizable, model give better results than standard model.

Secondly, after finishing the one tube and one pass modeling with different situations such as parallel, counter, temperature difference, inlet velocities, .....etc. then changing the model to multi-tubes with one pass and carry the same steps as previous model "one tube and one pass". With the same velocities and temperature as first case in the previous model. And start the solution Realizable, model is used with non-equilibrium wall functions. Thirdly, the last model which is "multi-tubes with two passes" the same steps as previous model with changing velocities and temperatures. These results describe the flow and temperature distributions more realistically as it would be shown in the following sections.

#### A. CFD Results for the first case:

The result of the first case of one tube and one pass heat exchanger as followings figures (9-14). It is observed that in the temperature chart the temperature has lowest value in the inlet of the x direction nearly fixed and the then reached its maximum value after the mid of the heat exchanger. The pressure chart within the x direction is reaches the peak (maximum value) after the mid of the heat exchanger.

The velocity with x direction has fixed value in the beginning then starts to decrease to the minimum value velocity in u direction with x direction is fixed in the inlet then reached the maximum value, then decrease linearly.

The velocity of v direction is the opposite of u direction as starts with fixed value then reached the lowest value after the mid of the heat exchanger, then increase linearly. The velocity

in w direction with x direction, nearly fixed value in the beginning then increases linearly with x direction.

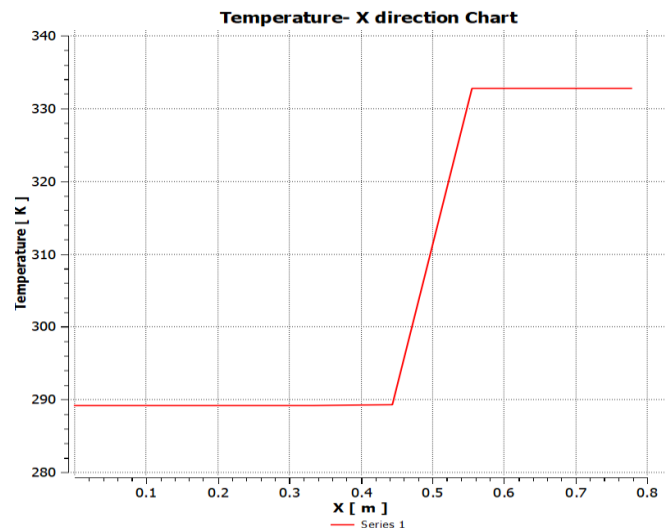

Figure 9. Temperature chart

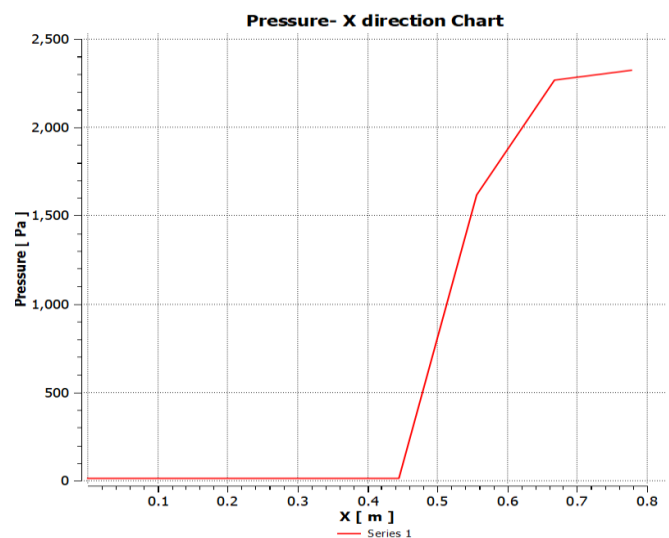

Figure 10. Pressure Chart

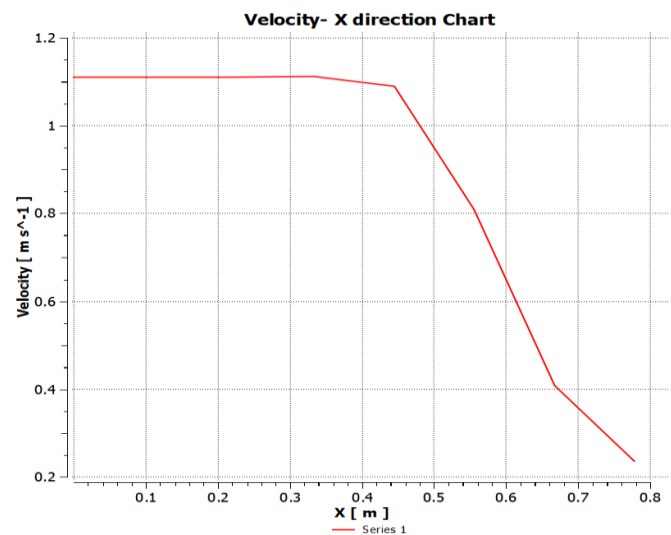

Figure 11. Velocity Chart.

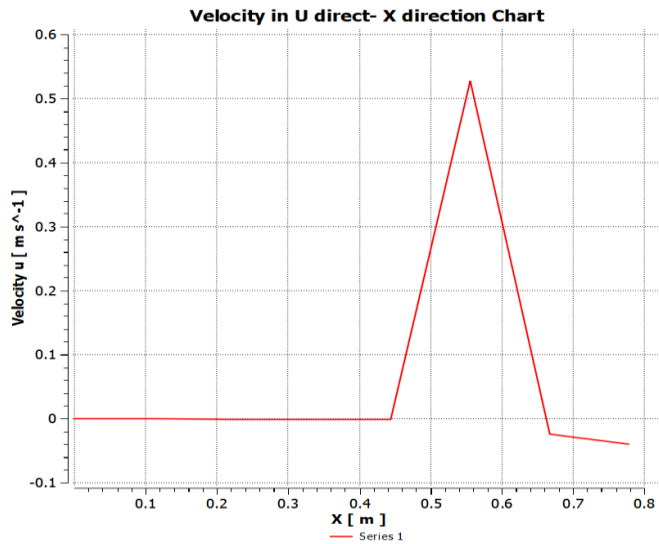

Figure 12. Velocity in direction U Chart

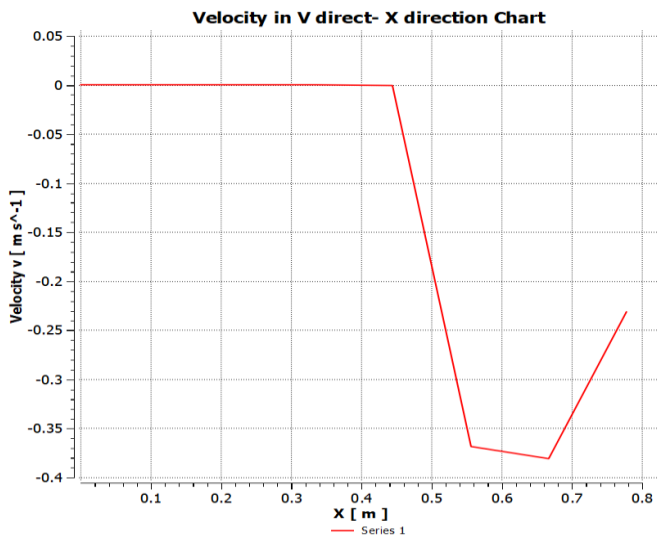

Figure 13. Velocity in direction v Chart.

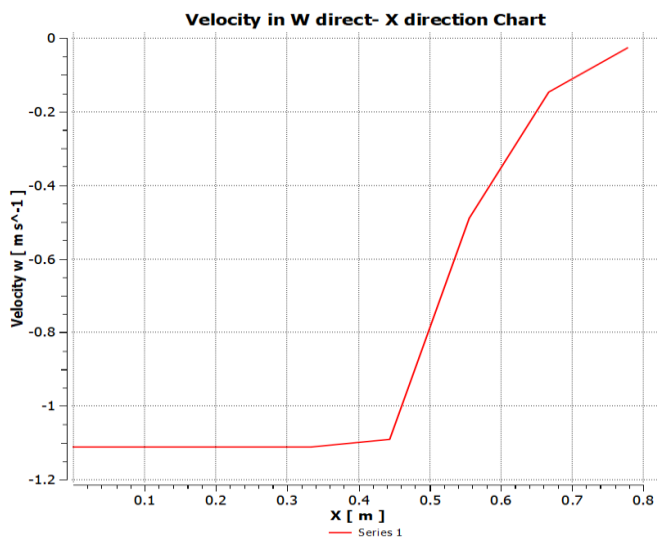

Figure 14. Velocity in direction w Chart

**B. Contour Plots for first case**

The temperature distribution along the heat exchanger for the second case can be seen through by the following figures (15-

18). Temperature contours are very useful to understand the heat transfer along with the flow distribution. The temperature contours are drawn across the cross section and along the length of heat exchanger at different positions. In order to understand the contours, following Figures 15 to 16 must be understood first.

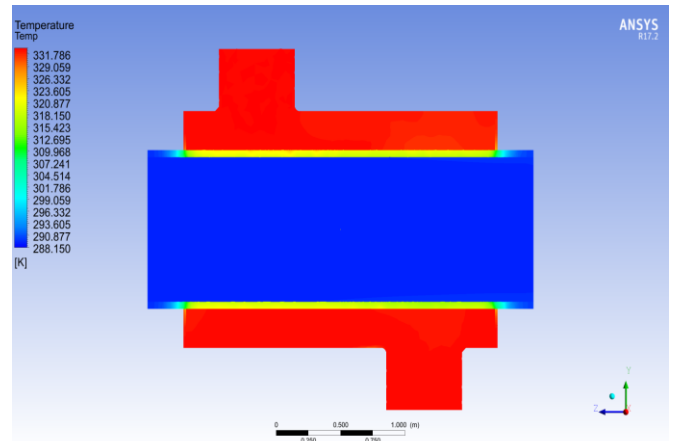

Figure 15 Temperature distribution on a plane for the shell & tube (Hot & cold fluid) in shell and heat exchanger for the first case.

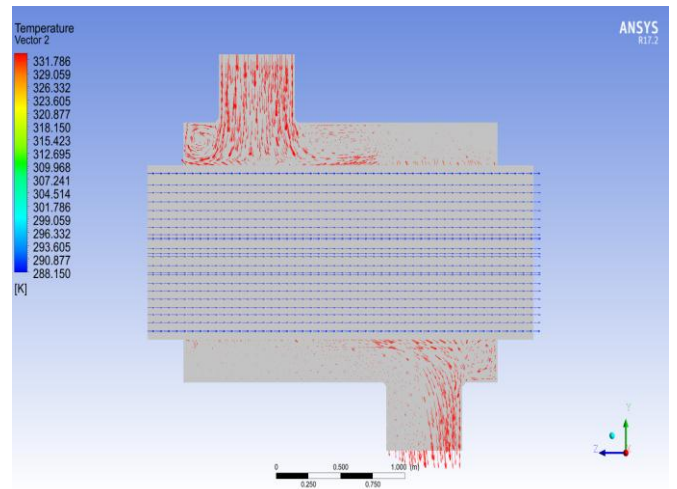

Figure 16 Direction of Temperature on a plane for the shell & tube (Hot & cold fluid) in shell and heat exchanger for the first case.

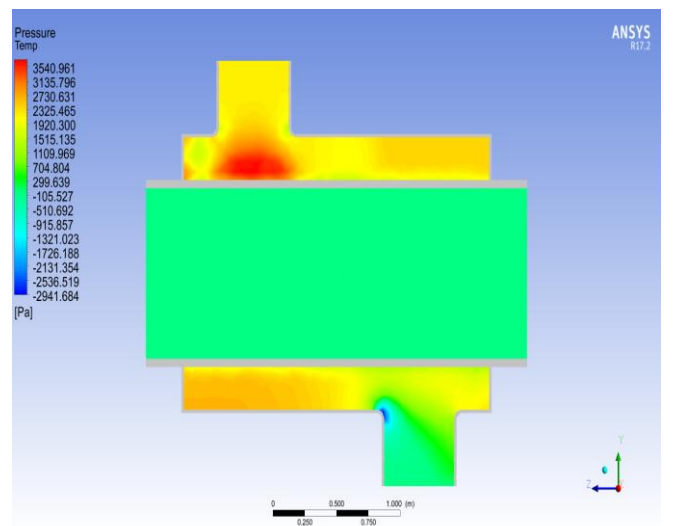

Figure 17. Pressure distribution on a plane for the shell & tube (Hot & cold fluid) in shell and heat exchanger for the first case.

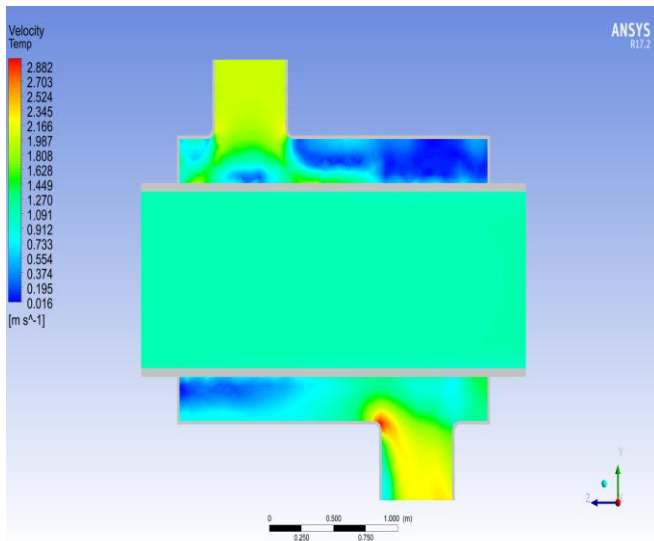

Figure 18 Velocity distribution on a plane for the shell & tube (Hot & cold fluid) in shell and heat exchanger for the first case.

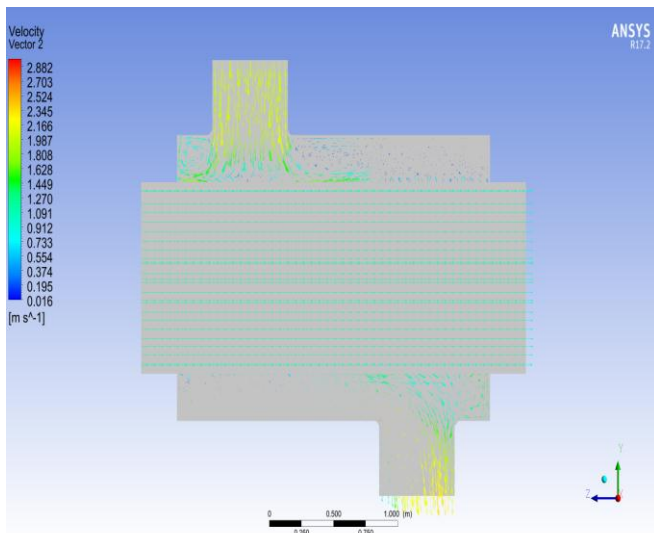

Figure 19 Direction of velocity on a plane for the shell & tube (Hot & cold fluid) in shell and heat exchanger for the first case.

It is observed that the fluid in the shell has the highest temperature in the inlet and the temperature decrease near the outlet of shell. However, in the tube side the temperature in the inlet is the lowest and then increase near the outlet of the tube.

In order to investigate the pressure distribution around shell and tube. In the shell side it's observed that the pressure is the highest after the inlet of the shell and the lowest in the outlet. In the tube side, the pressure is nearly the same along the tube.

The velocity distribution along shell side, the highest velocity as shown in the figure 18, is in the inlet and outlet of the shell. However, In the tube side, the velocity is nearly the same along the tube.

Before going into detailed discussions, velocity profile is examined to understand the flow distribution across the cross section at different positions in heat exchanger. above in Figure 19 is the velocity profile. It should be kept in mind that the heat exchanger is modeled considering the plane symmetry. Thus, the graph is showing only half the cross section of whole shell. As mentioned above the velocity

distribution along shell side, the highest velocity in the inlet and outlet of the shell. However, In the tube side, the velocity is nearly the same along the tube.

### C. CFD Results for the second case

The result of the second case of one tube and one pass heat exchanger as followings figures 20 and 21. It is observed that in the temperature chart the temperature has lowest value in the inlet of the x direction nearly fixed and the then reached its maximum value after the mid of the heat exchanger. The pressure chart within the x direction is reaches the peak (maximum value) after the mid of the heat exchanger. The velocity with x direction starts with fixed value then reached the lowest value after the mid of the heat exchanger, then increase linearly. The velocity in u direction with x direction, nearly fixed value in the beginning then increases linearly with x direction then decreased. The velocity of v direction starts with fixed value then reached the maximum value after the mid of the heat exchange.

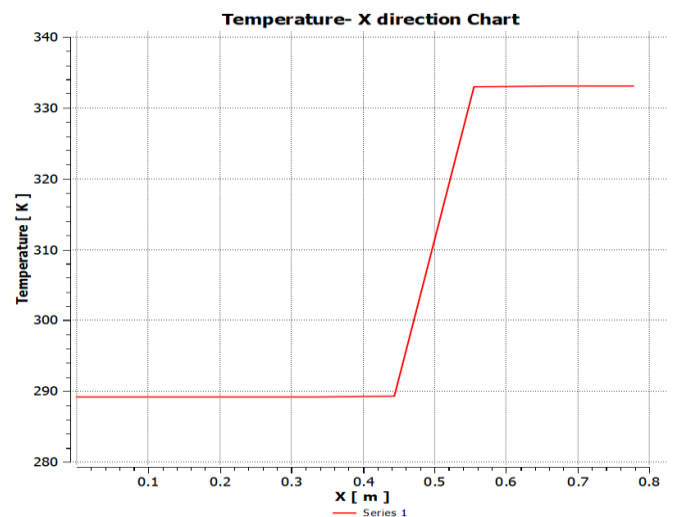

Figure 20. Temperature chart.

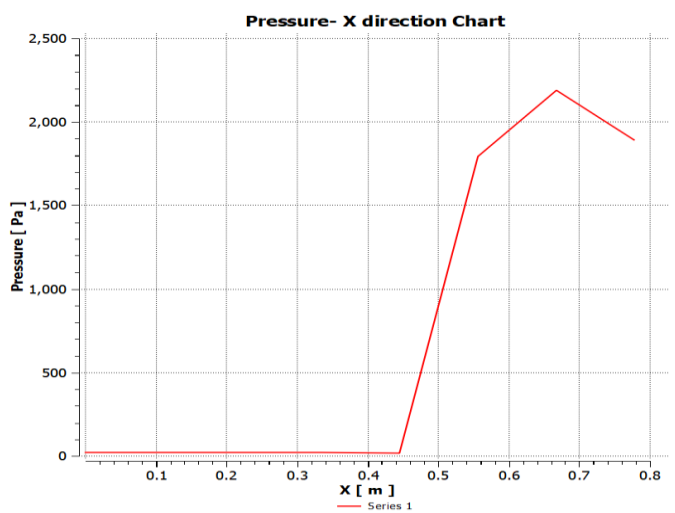

Figure 21. Pressure Chart

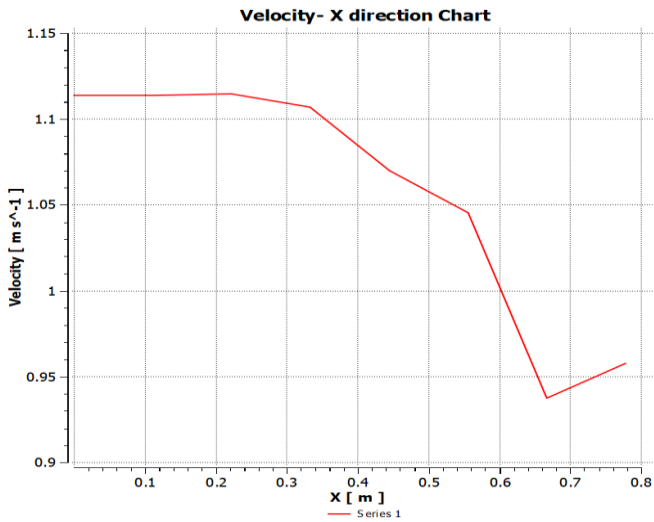

Figure 22. Velocity Chart

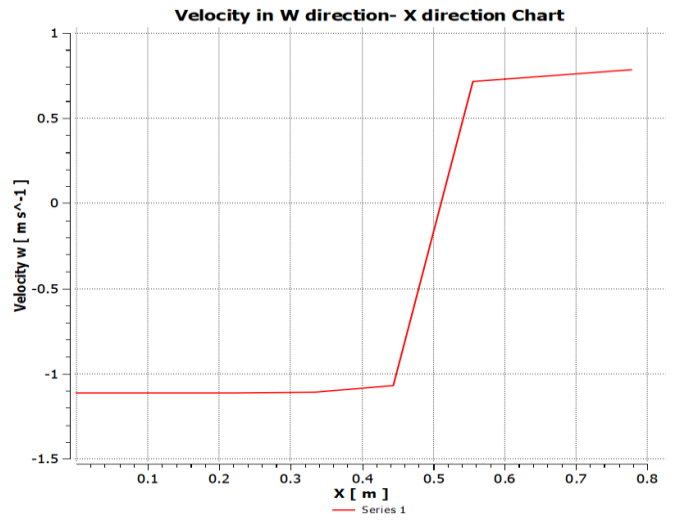

Figure 25. Velocity in direction w Chart.

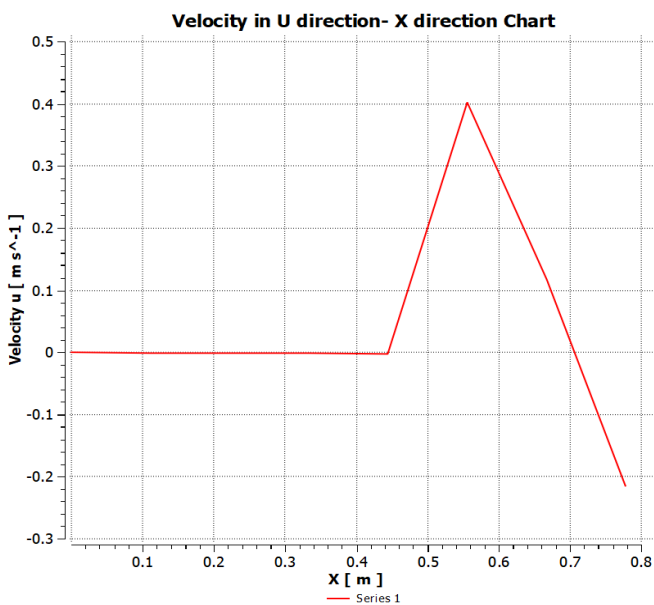

Figure 23. Velocity in direction U Chart

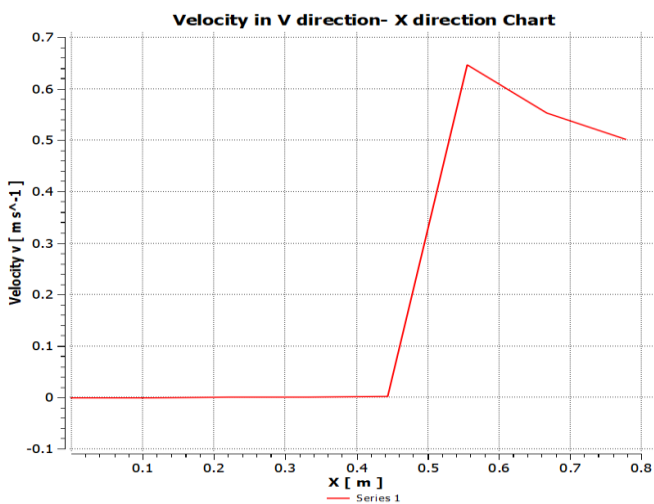

Figure 24. Velocity in direction v Chart.

The velocity in w direction with x direction, nearly the same as v direction which starts with fixed value in the beginning then increase linearly with x direction.

#### D. Contour Plots for second case

The temperature distribution along the Heat exchanger for the second case can be seen through by the following figures:

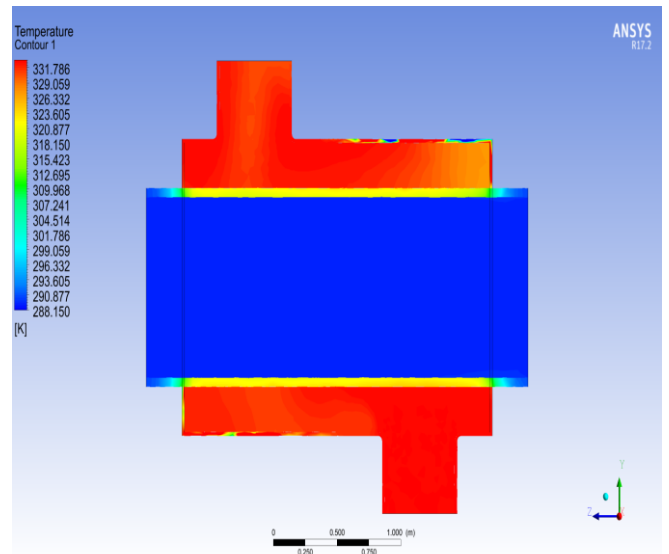

Figure 26. Temperature distribution on a plane for the shell & tube (Hot & cold fluid) in shell and heat exchanger for the fourth case.

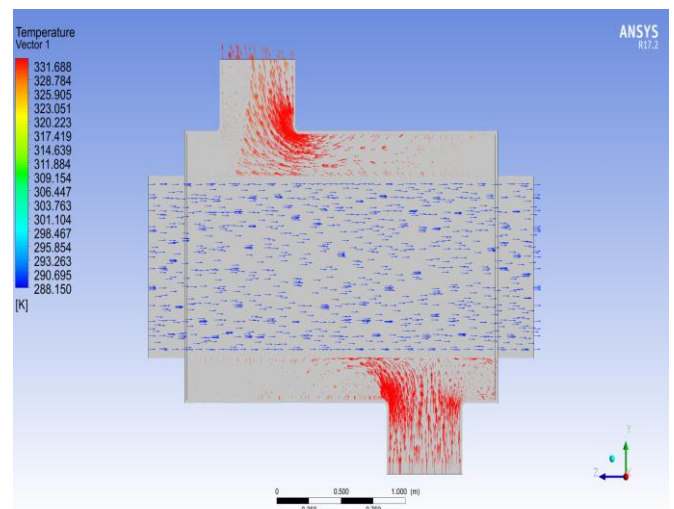

Figure 27. Direction of Tempe on a plane for the shell & tube (Hot & cold fluid) in shell and heat exchanger for the second case.

Temperature contours are very useful to understand the heat transfer along with the flow distribution. The temperature contours are drawn across the cross section and along the length of heat exchanger at different positions. In order to understand the contours, following Figures 26 to 27 must be understood first. It is observed that the fluid in the shell has the highest temperature in the inlet and the temperature decrease near the outlet of shell. However, in the tube side the temperature in the inlet is the lowest and then increase near the outlet of the tube.

In order to investigate the pressure distribution around shell and tube. In the shell side it's observed that the pressure is the highest after the inlet of the shell and the lowest in the outlet. In the tube side, the pressure is nearly the same along the tube.

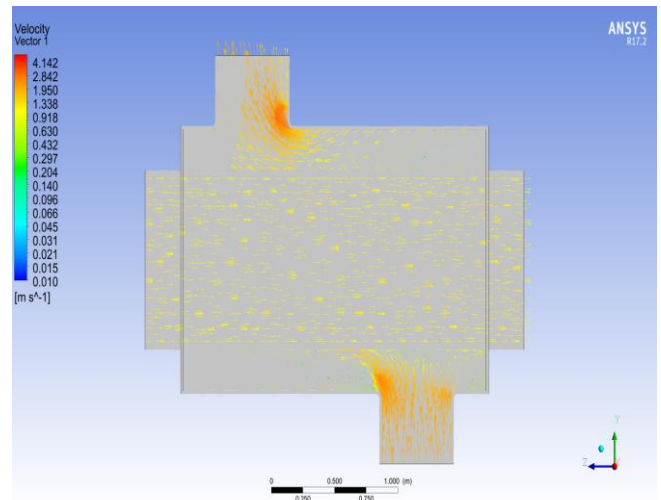

Figure 30. Direction of velocity on a plane for the shell & tube (Hot & cold fluid) in shell and heat exchanger for the second case.

The velocity distribution along shell side, the highest velocity as shown in the figure 29, is in the inlet and outlet of the shell. However, in the tube side, the velocity is nearly the same along the tube.

The above results based on the graph that is showing only half the cross section of whole shell. The velocity distribution along shell side, the highest velocity in the inlet and outlet of the shell. However, In the tube side, the velocity is nearly the same along the tube.

E. Summary for all cases

Two cases are evaluated to investigate the difference between different flow direction conditions in shell and tube heat exchanger with the same model, temperature profile along Heat exchanger for the two cases Figures 31.

This could be due to the several reasons including complicated geometry of the shell side and numerical diffusion. It is seen that the Temperature starts as fixed then increase linearly.

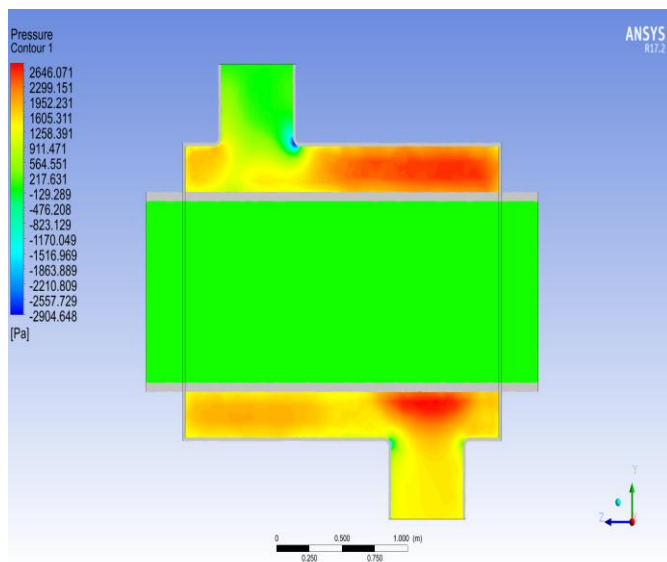

Figure 28. Pressure distribution on a plane for the shell & tube (Hot & cold fluid) in shell and heat exchanger for the second case

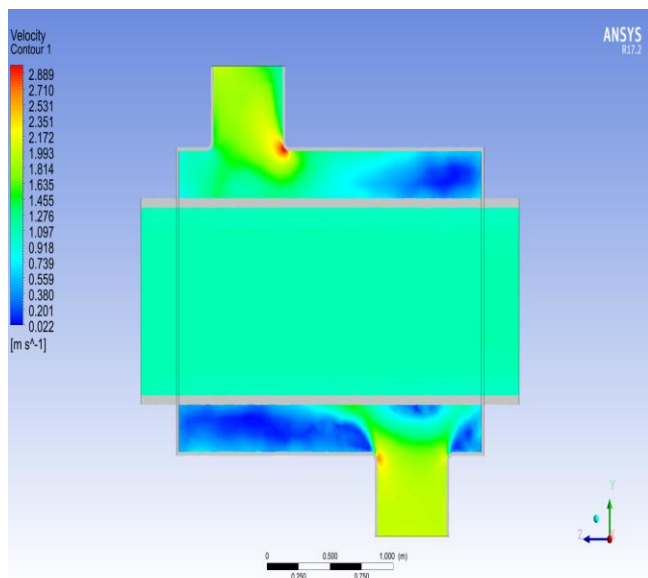

Figure 29. Velocity distribution on a plane for the shell & tube (Hot & cold fluid) in shell and heat exchanger for the second case.

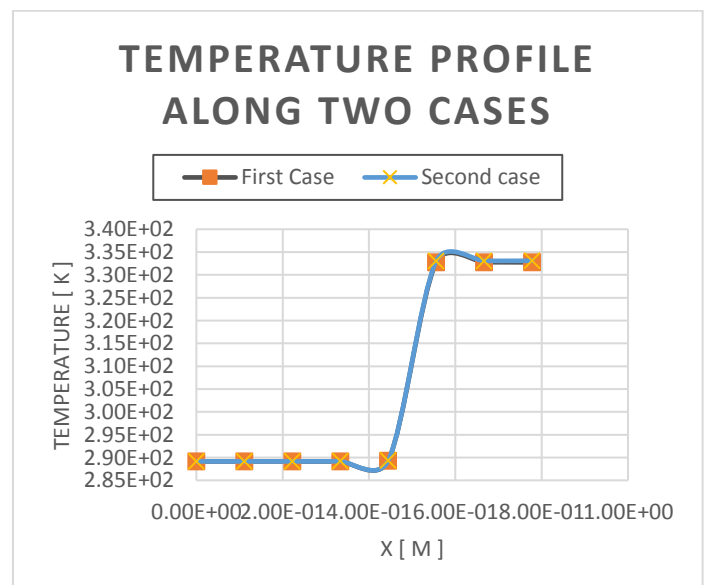

Figure 31. Comparison for temperature profile along Heat exchanger for the two cases.

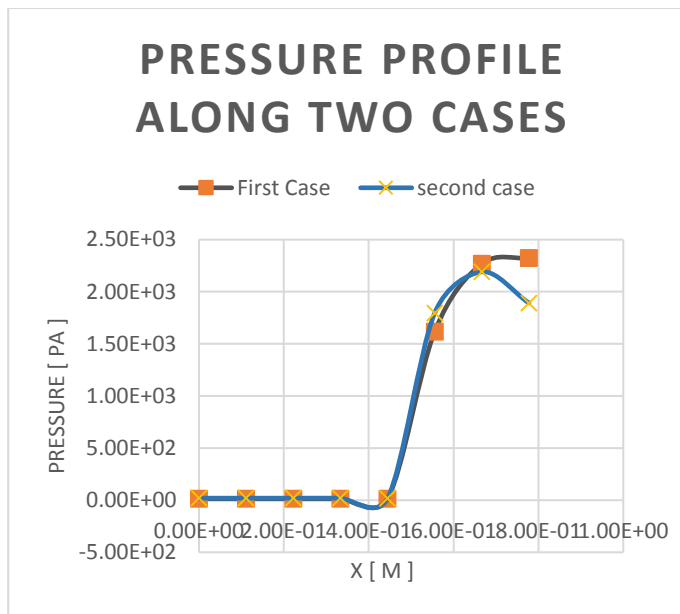

Figure 32. Comparison for pressure profile along Heat exchanger for the two cases.

This could be due to the several reasons including complicated geometry of the shell side and numerical diffusion. Whereas, the pressure drop in tube side (straight tubes) is predicted with an average error between 5-9%.

Comparison for pressure profile along Heat exchanger for the two cases can also be seen in the Figure 32. It is also been under-predicted by this model but still better than other models with an average error of 19-20%. The good thing about these results is the constant difference from experimental results and consistency with the real systems, i.e. with higher pressure drop, higher heat transfer is achieved.

The velocity profiles are very useful to understand the heat transfer along with the flow distribution. The temperature and velocity profiles are drawn across the cross section and along the length of heat exchanger at different positions. Whereas, the velocity profiles are drawn only across the cross section. In order to understand the velocity profiles, following Figure 33 must be understood first

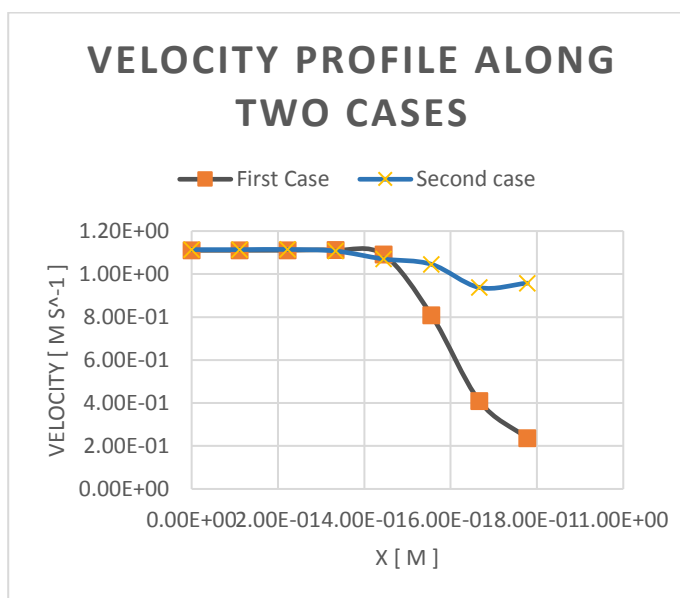

Figure 33. Comparison for Velocity profile along Heat exchanger for the two cases.

## VI.CONCLUSIONS

The heat exchanger performance is affected by several variables, namely the mass flow rate during the exchanger, its quality temperature, Temperature, hot and cold discharge, surface area available for heat transfer, thermal conductivity of pipe material, the degree of sediments or crusts inside the tubes of the heat exchanger and transient heat transfer coefficients from internal and external surfaces of pipes. The pressure loss through the heat exchanger is directly related to the required pumping capacity and is indirectly associated with the heat transfer coefficient.

So for the reasons listed above for designing shell and tube heat exchangers, The practical simulation of a designed model is very expensive, hence CFD is a tool which helps to simulate the process and thus eliminating the cost and for the development of a prototype based on study. So that It's accepted that CFD helps to design heat exchanger by varying the different variables very easily otherwise it's very difficult if done practically. CFD models or packages provide contours and data which predict the performance of heat exchanger design.

The heat transfer and flow distribution are discussed in detail and proposed in the designed model Described previously which is one tube with one pass. Each case predicts the heat transfer with an average error of 15:25%. Thus, the models still can be improved.

The key difference between counterflow and parallel flow heat exchanger is that counterflow heat exchanger is highly efficient because it can exchange a maximum amount of heat, whereas parallel flow heat exchanger is less efficient because it cannot exchange a high amount of temperature. In brief, the counterflow process is the opposite of the parallel flow process.

**Funding:** This research has not received any type of funding.

**Conflicts of Interest:** The authors declare that there is no conflict of interest.

## NOMENCLATURE

- $\Delta P_{en}$  = Pressure drop losses in entrance
- $\Delta P_{ex}$  = Pressure drop losses in exit
- $Kc$  = Entrance pressure drop coefficient
- $Ke$  = Exit pressure drop coefficient
- $\sigma$  = Minimum Flow area/ Frontal area=  $\frac{A_1}{A_2}$
- $G$  = Mass velocity ( $kg/m^2s$ )
- $\Delta P$  = Pressure Drop ( $P_a$ ) \
- $f$  = Fanning friction factor
- $L$  = Length of pipe (m)
- $\rho$  = Fluid density ( $kg/m^3$ )
- $D$  = Hydraulic diameter of pipe (m)
- $Nu$  = Nusselt number
- $Re$  = Reynolds number
- $Pr$  = Prandtl number
- $Q$  = heat transferred per unit time (kJ/h, Btu/h)
- $U$  = the overall heat transfer coefficient ( $kJ/h\cdot m^2 \cdot ^\circ C$ , Btu/h-ft<sup>2</sup>·°F)
- $A$  = heat-transfer area ( $m^2$ , ft<sup>2</sup>)
- $\Delta T_{lm}$  = log mean temperature difference ( $^\circ C$ ,  $^\circ F$ )
- $C_{p(t)}$  = liquid specific heat tube side,
- $C_{p(s)}$  = liquid specific heat shell side ( $kJ/kg\cdot^\circ K$ , Btu/lb·°F)
- $w$  = tube side flow W shell side flow ( $kg/h$ , lb/h)
- $T_1$  =inlet temperature for shell side fluid.
- $T_2$  =outlet temperature for shell side fluid.

- $t_1$  = inlet temperature for tube side.
- $t_2$  = outlet temperature for tube side.
- $R_{fi}$  and  $R_{fo}$  = fouling resistance of the inside and outside surfaces
- $R_{ft}$  = the total fouling resistance
- $A_f$  = fin surface area
- $\eta_f$  = fin efficiency
- $L$  = fin length
- $L_c$  = corrected fin length
- $D$  = the diameter of the cylindrical fins
- $A_o$  and  $A_i$  = the total surface area of the outer and inner surfaces
- $Q$  = Heat transfer rate, kW
- $m$  = Mass flow rate, kg/s
- $E$  = Total energy, kJ
- $h$  = Specific enthalpy, kJ/kg
- $C$  = Flow stream heat capacity rate, W/K
- $h_h$  = Hot side heat transfer coefficient ( $W/m^2.k$ )
- $h_c$  = Cold side heat transfer coefficient ( $W/m^2.k$ )
- $\Delta x$  = Exchanger tube wall thickness (m)
- $k$  = Exchanger wall material thermal conductivity ( $W/m.K$ )
- $R_f$  = Fouling coefficient ( $W/m^2.K$ )

## REFERENCES

- [1] R. K. Shah, and D. P. Sekulic, *Fundamentals of heat exchanger design*: John Wiley & Sons, 2003.
- [2] Y. Lei, Y. Li, S. Jing, C. Song, Y. Lyu, and F. Wang, "Design and performance analysis of the novel shell-and-tube heat exchangers with louver baffles," *Applied Thermal Engineering*, vol. 125, pp. 870-879, 2017.
- [3] M. M. Rashidi, I. Mahariq, M. Alhuyi Nazari, O. Accouche, and M. M. Bhatti, "Comprehensive review on exergy analysis of shell and tube heat exchangers," *Journal of Thermal Analysis and Calorimetry*, 2022/07/24, 2022.
- [4] C. Abeykoon, "Improving the performance of shell-and-tube heat exchangers by the addition of swirl," *International Journal of Process Systems Engineering*, vol. 2, no. 3, pp. 221-245, 2014.
- [5] S. Wang, J. Wen, and Y. Li, "An experimental investigation of heat transfer enhancement for a shell-and-tube heat exchanger," *Applied Thermal Engineering*, vol. 29, no. 11, pp. 2433-2438, 2009/08/01/, 2009.
- [6] L. He, and P. Li, "Numerical investigation on double tube-pass shell-and-tube heat exchangers with different baffle configurations," *Applied Thermal Engineering*, vol. 143, pp. 561-569, 2018/10/01/, 2018.
- [7] X. Gu, W. Chen, C. Chen, N. Li, W. Gao, and Y. Wang, "Detailed characteristics of fluid flow and its effect on heat transfer in shell sides of typical shell-and-tube heat exchangers," *International Journal of Thermal Sciences*, vol. 173, pp. 107381, 2022/03/01/, 2022.
- [8] O. Khayal, *Fundamentals of Heat Exchangers*, 2018.
- [9] A. C. Caputo, A. Federici, P. M. Pelagagge, and P. Salini, "On the design of shell-and-tube heat exchangers under uncertain operating conditions," *Applied Thermal Engineering*, vol. 212, pp. 118541, 2022/07/25/, 2022.
- [10] L.-Y. Chen, V. S. K. Adi, and R. Laxmidewi, "Shell and tube heat exchanger flexible design strategy for process operability," *Case Studies in Thermal Engineering*, vol. 37, pp. 102163, 2022/09/01/, 2022.
- [11] M. B. Slimene, S. Poncet, J. Bessrour, and F. Kallel, "Numerical investigation of the flow dynamics and heat transfer in a rectangular shell-and-tube heat exchanger," *Case Studies in Thermal Engineering*, vol. 32, pp. 101873, 2022.
- [12] F. Incropera, D. DeWitt, T. Bergman, and A. Lavine, *Fundamentals of Heat and Mass Transfer*, 2007.
- [13] A. L. Costa, and E. M. Queiroz, "Design optimization of shell-and-tube heat exchangers," *Applied thermal engineering*, vol. 28, no. 14-15, pp. 1798-1805, 2008.
- [14] E. Edreis, and A. Petrov, "Types of heat exchangers in industry, their advantages and disadvantages, and the study of their parameters." p. 012027.
- [15] M. E. Srinivasan S, Seenivasaperumal V, M.E2, Manikandan G, M.E3, "Heat Exchanger Design Modification for Performance Optimization Using CFD Tools," *International Journal of Applied Engineering Research*, vol. 13, 2018.
- [16] U. U. Rehman, "Heat transfer optimization of shell-and-tube heat exchanger through CFD studies," 2012.
- [17] A. Hanan, U. Zahid, T. Feroze, and S. Z. Khan, "Analysis of the performance optimisation parameters of shell and tube heat exchanger using CFD," *Australian Journal of Mechanical Engineering*, pp. 1-14, 2021.
- [18] B. Anderson, R. Andresson, L. Håkansson, M. Mortensen, R. Sudiyo, and V. W. BEREND, "Computational Fluid Dynamics for Chemical Engineers," *Gotheburg: un*, 2008.
- [19] E. Cao, *Heat transfer in process engineering*: McGraw-Hill Education, 2010.
- [20] J. Yang, L. Ma, J. Bock, A. M. Jacobi, and W. Liu, "A comparison of four numerical modeling approaches for enhanced shell-and-tube heat exchangers with experimental validation," *Applied Thermal Engineering*, vol. 65, no. 1-2, pp. 369-383, 2014.
- [21] A. A. Abd, M. Q. Kareem, and S. Z. Naji, "Performance analysis of shell and tube heat exchanger: Parametric study," *Case studies in thermal engineering*, vol. 12, pp. 563-568, 2018.
- [22] V. V. P. Dubey, R. R. Verma, P. S. Verma, and A. Srivastava, "Performance analysis of shell & tube type heat exchanger under the effect of varied operating conditions," *IOSR Journal of Mechanical and Civil Engineering (IOSR-JMCE)*, vol. 11, no. 3, pp. 08-17, 2014.
- [23] R. Shawabkeh, *Handout: Step-by-step for Heat Exchanger design*, 2015.
- [24] S. Rajasekaran, and T. Kannadasan, "A simplified predictive control for a shell and tube heat exchanger," *International Journal of Engineering Science and Technology*, vol. 2, no. 12, pp. 7245-7251, 2010.
- [25] A. Roy, and D. Das, "CFD analysis of a shell and finned tube heat exchanger for waste heat recovery applications," *International Journal of Mechanical & Industrial Engineering*, vol. 1, pp. 77-83, 2011.
- [26] A. Vyas, and M. P. Sharma, "An Experimental Analysis Study to Improve Performance of Tubular Heat Exchangers," *Int. Journal of Engineering Research and Applications*, vol. 3, pp. 1804-1809, 2013.
- [27] A. D. Jadhav, and T. A. Koli, "CFD analysis of shell and tube heat exchanger to study the effect of baffle cut on the pressure drop," *International Journal of Research in Aeronautical and Mechanical Engineering*, vol. 2, no. 7, pp. 1-7, 2014.
- [28] I. Nwokedi, and C. Igwegbe, "Design of Shell and Tube Heat Exchanger with Double Passes," *Journal of Engineering Research and Reports*, vol. 3, pp. 1-12, 11/01, 2018.
- [29] C. M. Narayan, and S. Das, "Computer Aided Design of Shell and Tube Heat Exchangers (Incorporating Most Recent Developments)," pp. 1-74, 2018.