

CO-OFDM Technology Long Distance Transmission System

Feng Xianjie^{1,3,*} and Li Yinfeng²

¹ School of Electronic Engineering, Dongguan University of Technology, Dongguan 523808, P. R. China

² School of Electronic Engineering, Beijing University of Posts and Telecommunication, Beijing 100876, P. R. China

³ School of Electronic Engineering, Jiangxi Science & Technology Normal University, Nanchang 330013, P. R. China

Received: 25 Apr. 2013, Revised: 26 Aug. 2013, Accepted: 28 Aug. 2013

Published online: 1 Mar. 2014

Abstract: Analysis of CO-OFDM single-mode optical fibre transmission system model, studied the timing deviation on the system synchronization performance, and used the Zadoff-Chu pilot sequence to realize the system synchronization, and concludes that the four QAM is to achieve 100 Gbps long distance transmission of the optimal modulation mode. In addition, the Zadoff-Chu pilot frequency sequence also has a constant amplitude, zero auto correlation properties, which can reduce the amplifier nonlinear effects, improve the performance of channel estimation. Based on Optisystem software simulation platform, built based on the CO-OFDM technology transfer rate for 100 Gbps long distance transmission system simulation system, and research the transmission distance for 1000 km error performance and the relationship between the transmission power. We research in single channel transmission and WDM transmission system of the two cases, random filling and consistent filling effect the performance of the system.

Keywords: CO-OFDM, Zadoff-Chu pilot frequency, sequence, Optisystem software, timing synchronization, random filling and consistent filling

1 Introduction

The traditional optical communication system using intensity modulated, static dispersion compensation scheme extends the transmission distance, which disadvantages of the scheme is: baseband signal intensity modulation of optical carrier directly spectrum utilization rate is low; we need to know every WDM fiber transmission channel of accumulation of dispersion, then can through the precise dispersion compensation match scheme solving dispersion effect, and no effective measures to solve dynamic dispersion compensation. So the traditional optical communication technology has been difficult to meet the current scheme reconfigurable optical network in the overall development trend [1].

In order to realize the long distance transmission system design, considering the OFDM systems and the superiority of the coherent communication system, combining with the advantages of both, this paper puts forward based on coherent light orthogonal frequency division multiplexing (namely CO-OFDM) technology transmission system model [2,3], It can make full use of

fiber-optic tremendous bandwidth resource, increase the transmission capacity, transmission efficiency, large capacity long distance transmission can save a large amount of fiber and the repeaters, thereby greatly reducing the transmission cost, and has good compatibility with existing network, expansion and convenient. For the few early core optical fiber system, using CO-OFDM technology, the system does not need to do more changes, and can easily expansion.

This paper, we uses the Optisystem software and Matlab software combination, establish transmission system simulation model, and select the single mode optical fiber as transmission link. We also research the system of multiple modulation, timing synchronization and transmission.

2 CO-OFDM Transmission System Theory

CO-OFDM system with OOFDM system diagram is similar [4], as shown in Fig. 1, which according to the OOFDM principle is divided into five parts, respectively:

* Corresponding author e-mail: fengxianjie@126.com

radio frequency (RF) OFDM sending end, electro-optical (RF-To-Optical, RTO) up converter, optical transmission link, electro-optical (Optical-To-RF OTR) down converter, and RF OFDM receiver down converter.

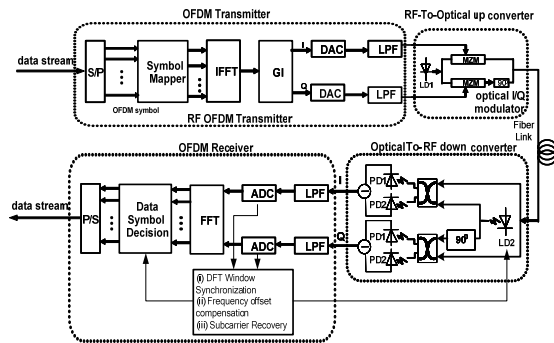

Fig. 1: CO-OFDM transmission system theory model

In the OFDM radio transmitter, a binary data stream through the constellation mapping, inverse Fourier transform (IFFT), add the pilot symbols, the training sequence and cyclic prefix, then the digital-analog conversion, filtering process, forming a baseband OFDM signal, and the modulated RF; electro-optical up converter (RTO) is the use of MZM (MZM: Mach-Zehnder Modulation) modulator for baseband OFDM signal external modulation, including modulation, phase modulation, shown on the map as a phase modulation, the RF modulating OFDM signal on a light carrier; optical transmission link by using optical fiber and used to compensate the link loss in EDFA composition; photoelectric down converter (OTR), where the use of optical coherent detection, using the two receiver for balanced homodyne detection, optical OFDM signal reduction for RF OFDM signal, complete the photoelectric conversion; in RF OFDM receiver, OTR output RF OFDM signal reduction into base band OFDM signal, followed by a baseband OFDM signal demodulation process, such as filter, a digital-to-analog conversion, timing synchronization, frequency compensation, carrier recovery and data signal processing, the final will be a baseband OFDM signal recovery the original binary data stream.

3 CO-OFDM Systems Doppler Frequency Shift and Zadoff Sequence of the Timing Synchronization

3.1 CO-OFDM Systems Doppler Frequency Shift will Bring Two Questions

First, in the direct conversion, composed of large frequency offset caused by RF signal maximum

frequency increases, causes the RF bandwidth expansion, thus receiving increased costs. In second, due to the direct down conversion of the intermediate frequency signal loss, subcarrier signal and the local laser frequency overlap leads to the drop of system performance.

In the CO-OFDM system, the frequency synchronization process can be divided into two stages: frequency acquisition and frequency tracking. Frequency capture is designed first rough on the frequency offset can be estimated, to simplify the CO-OFDM system received signal processing process, also known as the rough estimation; frequency tracking is usually based on rough estimate has been made based on the determined frequency offset value and compensation, also known as fine estimation.

3.2 Zadoff-Chu Sequence Timing Synchronization

CAZAC sequence [5,6] with constant amplitude, zero correlation of the good characteristics can reduce the influence of nonlinear amplifier, can improve the OFDM systems synchronization and channel estimation performance, and Zadoff-chu is the most widely used a CAZAC sequence. Zadoff-Chu pilot sequence according to the formula (1) generation:

$$a_k = \begin{cases} W_N^{k^2/2+qk}, & k \text{ is odd} \\ W_N^{k(k+1)/2+qk}, & k \text{ is even} \end{cases} \quad (1)$$

$$W_N = \exp(-j2\pi r/N), \quad j = \sqrt{-1};$$

Among them: q is any integer, R and N are prime integer. For $R = 3$, $q = 0$, $N = 200$, ZC sequence correlation properties as shown in Fig. 2, the correlation value at zero for a single sharp peak, the rest of the correlation value is almost zero, correlation is very good.

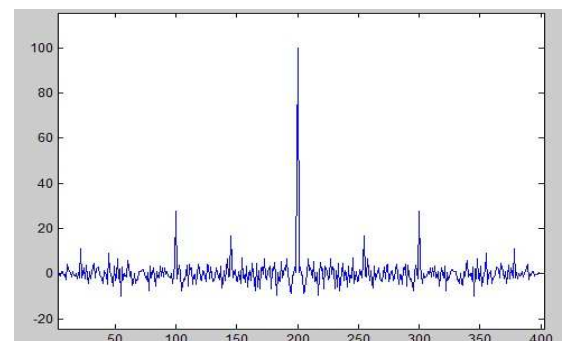

Fig. 2: Zadoff-Chu pilot sequence correlation properties

Using Matlab software to deal with the correlation between data signals and pilot sequence, as shown in Fig.

3, the last two graph respectively OFDM symbol timing sampling, their peaks are the optimal timing of sampling points, which can achieve very good timing effect. In order to more intuitive that Zadoff-Chu pilot sequence synchronization based on the efficiency of the algorithm, the following are OFDM demodulation of the output after constellation chart. Fig. 4 is to use QAM modulation and demodulation when output. Fig. 4 shows, by adding Zadoff-Chu pilot sequence, CO-OFDM system synchronization effect is very good.

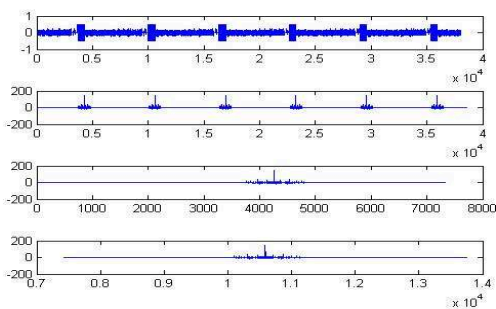

Fig. 3: ZZadoff-Chu pilot sequences timing effect simulation diagram

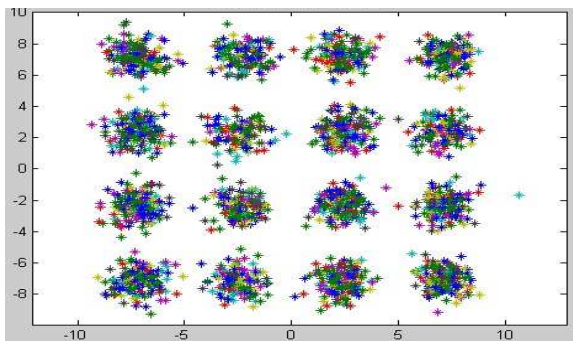

Fig. 4: Using 16 QAM modulation and demodulation of the OFDM constellation diagram

In order to obtain stable and reliable synchronization, in the CO-OFDM system [7], used in transmitting data front insert special training sequence method, although the training symbol insertion brings the resource utilization rate of decline, but at the expense of transmission efficiency for the cost in exchange for symbol timing synchronization speed increase, and synchronization accuracy and stability, or very worthwhile. Because CO-OFDM technology is a new technology developing in recent years rapidly, it is not

very suitable for CO-OFDM system timing synchronization algorithm, so we can only refer to some classic algorithms in wireless communication.

4 100 GBPS Long Distance Transmission System Based on the CO-OFDM Technology

4.1 100 Gbps CO-OFDM Systems Structure Diagram

Duo to polarization mode multiplexing technique can make system transmission capacity double, and directly into high data throughput, without lowering the reliability of data transmission, therefore, the polarization mode multiplexing technique gradually become hotspot in recent years.

Based on the above research and analysis, the paper Optisystem software built OBM based on the PDM and technology 100 Gbps CO-OFDM transmission simulation system, as shown in Fig. 5.

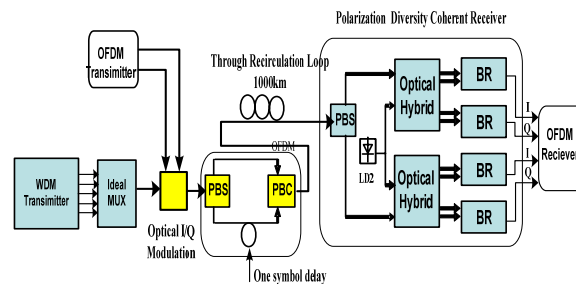

Fig. 5: The 100 Gbps CO-OFDM system diagram

4.2 Produced At the Transmitting End of the System

We use the wavelength multiplexing method of generating interval of 5 different wavelengths of light carrier, the OFDM spectrum into multiple orthogonal frequency band. WDM transmitter output and the spacing of the five optical carrier, laser diode wide set to 100 kHz, WDM channel interval set to 50 GHz.

4.3 Produced Pseudo-Random Binary Sequences; 4QAM Modulation by Matlab Software

Every single band OFDM signal is produced as the same with 10 Gbps system, the use of parameters are

consistent, are made by Matlab software produced by $2^{15} - 1$ length pseudo-random binary sequence, and then through the 4QAM modulation, then by IFFT transform. The baseband OFDM symbol rate of 10Gbps, IFFT of length 512, parallel subcarrier number is 256, the guard interval (i.e. cyclic prefix) of length 64, each frame having a 10 OFDM signal, uses the massive pilot insertion method, a frame is inserted into the 1 pilot signal, i.e., each of the 10OFDM signal group pilot, pilot signal used for synchronization and channel estimation.

4.4 Symbol Period Delay and Polarization Beam Combiner(PBC)

As each OFDM symbol delay a symbol period [7,8], so the two polarization direction independent completely. two signal passes through the polarization beam combiner (PBC) into a signal through the optical fiber loop transmission. At this time of each sub-band transmission rate is 20Gbps, transmission data of the same, so the 5 sub-bands total transmission rate of 100Gbps.

4.5 Optical Fiber Loop

Optical fiber loop by 10 class 100 km single-mode optical fiber and EDFA which are connected in series, EDFA on fiber link loss compensation. Optical parameter is set to: light dispersion and ps/nm/km, loss of 0.2-dB/km, set to 20 dB EDFA gain, noise factor for 6 dB.

4.6 At the Receiving End of the System

On the computer, the use of MIMO-OFDM model of Matlab software procedures, including: the use of timing synchronization method of determining OFDM symbols starting position to determine the FFT window integral interval, channel estimation and 4QAM demodulation, and draw each carrier constellation and bit error rate calculation.

5 100 GBPS Long Distance Transmission System Simulation Results and Analysis

5.1 The Curve between Transmit Power and Bit Error Rate

We are in the first sub carrier as example, analysis of the relationship between laser transmit power and bit error rate, Fig. 6 is transmission distance of 1000 km, the relation curve between power and Q factor, Fig. 6 shows the transmit power to -1dBm, the CO-OFDM system bit error rate minimum.

5.2 100 Gbps Back-to-Back Transmission Distance 1000 km, the CO-OFDM System Error Performance

Based on the above conclusion, the transmitter power is set to 1dBm, this paper analyzes the 100Gbps CO-OFDM transmission system back to back transmission and transmission distance is 1000km BER performance, as shown in Fig. 6, the BER is the average of the five sidebands BER. The Fig. 7, Back to Back transmission system error performance as 10^{-3} , light signal-to-noise ratio is 15.4 dB, and the corresponding fiber optic link for 1000 km, light signal-to-noise ratio is 16.7 dB. Increase light SNR, BER performance will improve.

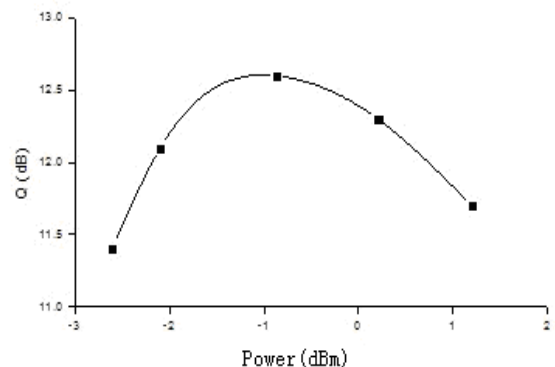

Fig. 6: 100 Gbps CO-OFDM transmit power and the bit error rate relationship chart

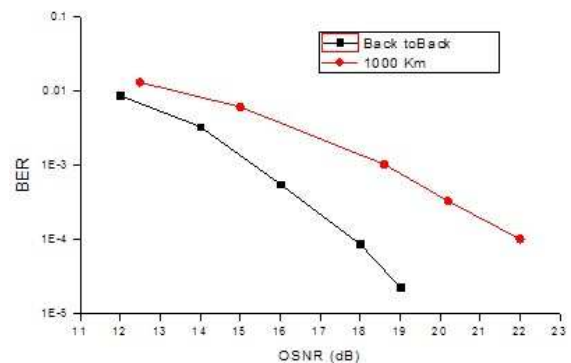

Fig. 7: BER performance will improve

6 Consistent Filling, Random Filling

6.1 Consistent Filling, Random Filling

In the simulation, if five OFDM sidebands multiplexed to produce by the same data, this is called consistent filling. We have a problem: consistent filling will be reduced to the nonlinear system, so as to improve CO-OFDM systems transmission performance? For this, we put forward another random filling scheme to contrast with, namely each sideband using different data. The comparison of two kinds of results, will be more persuasive.

6.2 Polarization Multiplexed 2x2 MIMO CO-OFDM Diagram

As shown in Fig. 8, two optical OFDM signal generates by two OFDM transmitter respectively, followed by the beam polarization splitter for merging, input to the wavelength division multiplexer channel. In order to ensure consistent with prior simulation environment, fiber optic link by 10 section 100 km of single-mode optical fiber and of EDFA, EDFA used to compensate the link loss. After 1000km optical fiber link, a signal input to an optical coherent receiver, variable frequency conversion under the photoelectric: every single band OFDM signals are generated length $2^{15} - 1$ pseudo random binary sequence by the Matlab software, and then through the 4QAM modulation, then by IFFT transform.

The baseband OFDM symbol rate of 10Gbps, IFFT of length 512, parallel subcarrier number is 256, protect the interval(i.e. circulation prefix) of length 64, each frame having a 10 OFDM signal, uses the massive pilot insertion method, a frame is inserted into the 1pilot signal, namely each of the ten OFDM signal having a group pilot. Optical parameter is set to: light dispersion 16ps/nm/km, loss of 0.2- dB/km, EDFA gain is set to 20dB, noise factor for 6 dB. Phase noise and channel estimation using pilot frequency inserting sequence manner.

6.3 Two Kinds of Filling Methods of Comparison

For consistent filling, in front of five sub-sidebands are using the same data. This system adopts random filling, data signals are mapped to the subcarriers when there is no correlation.

Using a single channel transmission, consistent filling optimal transmit power difference of 1dBm, Q factor is 1.4dB, while in WDM transmission system, an optimal transmit power the same are 1dBm, Q factors differ only in 0.3dB. The transmit power is -1dBm, can be randomly packed and uniform fill factor Q less than 0.5dB.

Whether in single channel transmission link or in WDM transmission system, random filling simulation performance better than consistent filling.

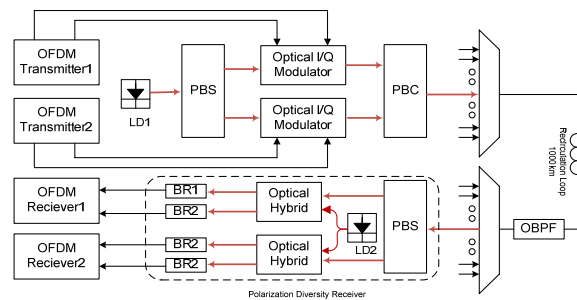

Fig. 8: Polarization multiplexed 2x2 MIMO CO-OFDM

7 Conclusion

CO-OFDM technology will high speed signals divided into several parallel of low speed signal in the time domain, and channel will be divided into several is channel in the frequency domain, the formation of parallel path carrier, and the subcarrier are mutual orthogonal. Through each path of low velocity signal will be modulated to different subcarrier, realize low speed signal in each sub channel of low bit rate parallel transmission. For the low speed parallel subcarrier, because the symbol period stretching, delay spread effect is relatively reduced, at the same time can be inserted in each symbol of protection time, the receiving end of optical fiber dispersion causes inter symbol interference (ISI) can almost be ignored [9,10]. Therefore, in the transmission process does not need complex dispersion management and anti-nonlinear techniques, the receiver only needs to be balanced and synchronization, simplifies the digital signal process, which reduces the network complexity and the cost of network building, also has no ISI information transmission.

Thus, CO-OFDM technology will have a wide application prospect.

Acknowledgements

This work is partially supported by the Dongguan Municipal Science and Technology Bureau “Mobile WiMAX system the key technology research” project funded, which project number: 2008108101006; the another is the Education Department of Jiangxi province project funded “For 4G mobile communication technology in the software defined radio”, which project number: [2007]284. We are greatly appreciated!

References

- [1] Massart Thierry, Meuter Cedric, V B Laurent. On the complexity of partial order trace model checking, *Inform. Process. Lett.*, **106**, 120-126 (2008).
- [2] W. Shieh. PMD-supported coherent optical OFDM systems, *IEEE Photonics Technology Letters*, **19**, 134-136 (2007).
- [3] C. William Gear, *Numerical Initial Value Problems in Ordinary Differential Equations*, Prentice Hall PTR Upper Saddle River, NJ, USA, (1971).
- [4] Yiran Ma, and William Shieh. Bandwidth-Efficient 21.4 Gb/s Coherent Optical 2×2 MIMO OFDM Transmission, *OFC/NFOEC, JWA59*, (2008).
- [5] Tamer Shahwan and Raed Said, A Comparison of Bayesian Methods and Artificial Neural Networks for Forecasting Chaotic Financial Time Series, *Journal of Statistics Applications & Probability*, **1**, 89-100 (2012).
- [6] Y. Han and G. Li. Coherent optical communication using polarization multiple-input-multiple-output, *Opt. Express*, **13**, 7527-7535 (2005).
- [7] Ilyas Saleem, Hamza Nawaz, Istaqlal Ahmed, S. Muzahir Abbas, Analytical Evaluation of Tri-band Printed Antenna, *Information Sciences Letters*, **1**, 85-89 (2012).
- [8] Mary Iwundu and Polycarp Chigbu, A Hill-Climbing Combinatorial Algorithm for Constructing N-Point D-Optimal Exact Designs, **1**, 133-146 (2012).
- [9] Bo Zhang and Zhicai Juan, Modeling User Equilibrium and the Day-to-day Traffic Evolution based on Cumulative Prospect Theory, *Information Science Letters*, **1**, 9-12 (2013).
- [10] Yanguo Michael Liu, Properties for Security Measures of Software Products, *Applied Mathematics & Information Sciences(AMIS)*, **1**, 129-156 (2007).



Feng Xianjie received the MS degree in Measuring and testing technology and instruments from Nanjing University of Science and Technology in 1995, and the PhD degree in Physical electronics from the department of Optics Engineering, Southeast University in 2002. He is currently a professor of Dongguan University of Technology. His research interests are in the areas of 4G wireless network, optical fiber communication system.

Li Yinfeng is the study of the wireless optical transmission system. She received MS degree from Beijing University of Posts and Telecommunications in 2011. Now, she is an engineer of Ericsson.