

2023

Arabic Educational Neural Network Chatbot

Bayan A. Alazzam

Faculty of Engineering and IT, The British University in Dubai, Dubai, UAE, 20197461@student.buid.ac.ae

Manar Alkhatib

Faculty of Engineering and IT, The British University in Dubai, Dubai, UAE, 20197461@student.buid.ac.ae

Khaled Shaalan

Faculty of Engineering and IT, The British University in Dubai, Dubai, UAE, 20197461@student.buid.ac.ae

Follow this and additional works at: <https://digitalcommons.aaru.edu.jo/isl>

Recommended Citation

A. Alazzam, Bayan; Alkhatib, Manar; and Shaalan, Khaled (2023) "Arabic Educational Neural Network Chatbot," *Information Sciences Letters*: Vol. 12 : Iss. 6 , PP -.

Available at: <https://digitalcommons.aaru.edu.jo/isl/vol12/iss6/54>

This Article is brought to you for free and open access by Arab Journals Platform. It has been accepted for inclusion in Information Sciences Letters by an authorized editor. The journal is hosted on [Digital Commons](#), an Elsevier platform. For more information, please contact rakan@aarj.edu.jo, marah@aarj.edu.jo, u.murad@aarj.edu.jo.

Arabic Educational Neural Network Chatbot

Bayan A. Alazzam*, Manar Alkhatib and Khaled Shaalan

Faculty of Engineering and IT, The British University in Dubai, Dubai, UAE

Received: 13 Mar. 2023, Revised: 2 May 2023, Accepted: 4 May 2023

Published online: 1 Jun. 2023

Abstract: Chatbots (machine-based conversational systems) have grown in popularity in recent years. Chatbots powered by artificial intelligence (AI) are sophisticated technologies that replicate human communication in a range of natural languages. A chatbot's primary purpose is to interpret user inquiries and give relevant, contextual responses. Chatbot success has been extensively reported in a number of widely spoken languages; nonetheless, chatbots have not yet reached the predicted degree of success in Arabic. In recent years, several academics have worked to solve the challenges of creating Arabic chatbots. Furthermore, the development of Arabic chatbots is critical to our attempts to increase the use of the language in academic contexts. Our objective is to install and create an Arabic chatbot that will help the Arabic language in the area of education. To begin implementing the chatbot, we collected datasets from Arabic educational websites and had to prepare these data using the NLP methods. We then used this data to train the system using a neural network model to create an Arabic neural network chatbot. Furthermore, we found relevant research, conducted earlier investigations, and compared their findings by searching Google scholar and looking through the linked references. Data was gathered and saved in a json file. Finally, we programmed the chatbot and the models in Python. As a consequence, an Arabic chatbot answers all questions about educational regulations in the United Arab Emirates.

Keywords: Chatbot; Arabic Language; Artificial intelligent; Neural network.

1 Introduction

A chatbot is an Artificial Intelligence (AI) system that can imitate a natural language interaction with a user through messaging applications, websites, mobile apps, or over the phone. Chatbots may aid with a variety of consumer interactions, including customer support and product reporting. One of the most intriguing natural language AI applications is chatbots. They are thought to be intelligent conversational agents that seek to talk with a human partner, acting as a virtual assistant that interacts with people by simulating human interaction and employing natural language [1]. Furthermore, chatbots for many disciplines and languages have been created. The chatbot is utilized in a variety of related applications, including customer service, translation, and home automation; however, the chatbot is most often employed in online commercial applications [2]. Chatbots are divided into two types: dialogic chatbots and rule-based chatbots. The dialogic chatbot is most often seen on websites and social media applications, where it evaluates input language utilizing NLP technology and features to discover the best match for the user. Rule-based chatbots, on the other hand, save the user's input inquiries and requests; based on external information, it is often employed in the health industry. People are interested in chatbots because they may provide quick help, obtain information, and get a response from a customer care service [3]. In this work, we address some of those challenges by proposing a deep learning approach for the real-time Arabic chatbot that answers all the students' questions related to the regulations of Ministry of Education such as: Exams time, new term date... etc.

In Section 2 is the background, we provide a detailed of our Deep Learning chatbot approach. We then discuss the related work in the field of neural network and Arabic chatbot in Section 3. Section 4 focuses on the Arabic language, providing an overview of the language and its main versions. Following that, Section 5 outlines the concept of Chatbot and its various applications. In Section 6, we critically analyze the Model Architecture, present the evaluation results and conclude the paper in section 7.

* Corresponding author e-mail: 20197461@student.buid.ac.ae

2 Background

Artificial intelligence algorithms may be used to create computers that can comprehend natural language, understand human intent, and make judgments without explicit direction [4,5]. These techniques have been employed in several areas, including natural language processing [6], computer vision [7], and robotics [8,9]. AI has the potential to address complicated issues [10,11]. AI algorithms may be used to categorize photos [12], find data patterns [13], and recognize voice [14]. AI algorithms have also been used to solve problems in fields as diverse as medicine [15,16], finance [5,17], and robotics [7,8,9]. Chatbots, AI-powered programs that can communicate with people naturally, have been created using AI [11]. Chatbots employ artificial intelligence algorithms to analyze and react to human input such as text or voice instructions, and they may deliver automated replies to inquiries and tasks. Chatbots have grown in popularity owing to their ability to respond quickly and accurately to user enquiries. Chatbots powered by AI may also give consumers with customized experiences by giving personalised replies based on user preferences and previous interactions. Artificial intelligence and chatbots have been utilized to enhance the user experience on educational websites [6,5,11]. AI algorithms may evaluate user data and deliver customised recommendations and suggestions, whilst AI-powered chatbots can provide automatic replies to user questions as well as personalized experiences based on user data. AI and chatbots, which can deliver customised suggestions and personalized experiences for users in any language, have the potential to improve the user experience on Arabic educational websites [6,5,11]. Chatbots powered by artificial intelligence have been deployed to enhance user experience on Arabic educational websites. Chatbots enabled by AI may deliver automatic solutions to user questions in a conversational way [11]. This enables them to respond to student inquiries swiftly and properly, regardless of the language. Furthermore, AI-powered chatbots may be utilized to give users with customized experiences, such as giving personalised information based on their data and previous interactions. Chatbots may also be utilized to grade student essays and tasks automatically, giving students with quicker and more accurate feedback [13].

Artificial Neural Networks (ANNs)

Artificial Neural Networks (ANNs) are machine learning techniques that are inspired by the form and operation of biological neural networks. These networks are made up of linked neurons that can analyze input, learn from it, and make choices without the need for explicit programming [7]. Artificial Neural Networks (ANNs) have been extensively used in a variety of applications, including object recognition [12] speech recognition [14], natural language [18], and computer vision [7]. ANNs have grown in prominence in recent years because to their capacity to handle complicated issues [10,11]. ANNs have allowed the creation of systems that can successfully identify pictures [12], detect patterns in data [13], and recognize speech [14]. ANNs have also been used in medical Lipton et al., 2016; [16], finance [5], Chiu et al., 2019; [17], and robotics [7,8,9].

Despite its promise, there are significant disadvantages to using ANNs. Training ANNs necessitates a large quantity of data and may be computationally demanding [6,8]. Additionally, ANNs are susceptible to overfitting, which may result in poor generalization performance ([12]). Furthermore, ANNs lack interpretability, making understanding the rationale behind their conclusions challenging [5,10,11].

To summarize, ANNs are strong machine learning techniques that may be used to create systems capable of effectively identifying objects, finding patterns in data, and interpreting natural language. ANNs have been used in a variety of industries, including medical, finance, and robotics, because to their potential. Despite significant issues and limits, ANNs continue to be a powerful tool for machine learning. Overall, ANNs have transformed how machines analyze and interpret data. Systems that can reliably categorize pictures, find patterns in data, and recognize voice may be constructed by exploiting their capability. Furthermore, ANNs may be utilized to tackle issues in a variety of sectors, including medical, finance, and robotics. Despite significant obstacles and limits, ANNs are a strong machine learning technique that may be utilized to create systems with improved accuracy and efficiency.

Natural Language Processing (NLP)

Artificial intelligence (AI)-powered chatbots have been used to enhance natural language processing (NLP) on Arabic websites Guo et al., 2020 [6,5,11]. The capacity to interpret and analyze human language, as well as recognize the meaning of words, phrases, and sentences, is referred to as NLP. AI algorithms may be used to evaluate user data and give users with personalized recommendations and suggestions [10,17]. Furthermore, AI algorithms may be used to find trends in user data and deliver customized experiences for users, such as tailoring material to their interests and preferences [12,14]. Chatbots have also been used to enhance natural language processing on Arabic websites [11]. Chatbots enabled

by AI may deliver automatic solutions to user questions in a conversational way [8,9]. This enables them to respond to student inquiries swiftly and properly, regardless of the language. Furthermore, AI-powered chatbots may be utilized to give users with customized experiences, such as giving personalised information based on their data and previous interactions [15,16]. Overall, AI and chatbots have the potential to completely transform how NLP is utilized on Arabic websites [5]. Systems that deliver personalised suggestions and personalized experiences for users in any language may be constructed by using the power of AI. Furthermore, AI-powered chatbots may be utilized to respond to user enquiries fast and correctly, regardless of language, enhancing the user experience.

Challenges and Limitations of Arabic NLP

Arabic Natural Language Processing (NLP) is a rapidly expanding research field that seeks to enable machines to comprehend and generate Arabic text. Despite recent advancements, there are a number of obstacles and limitations that make it difficult to implement NLP to the Arabic language effectively. Arabic's morphological and syntactic complexity is one of the greatest obstacles to Arabic NLP. Arabic is a highly inflected language with a complex morphology and syntax that makes it challenging to comprehend. In addition, Arabic has a large number of dialects, each with its own distinct characteristics, making it challenging to create a singular model that encompasses all the nuances of the language. In addition, there is a lack of annotated training datasets for Arabic NLP. However, the availability of annotated datasets for Arabic is still comparatively limited, making it difficult to train accurate models. Insufficient resources exist for parsing and generating Arabic text, further complicating the development of effective models. The absence of standard evaluation methods for tasks such as semantic similarity makes it difficult to measure the performance of models with precision. In addition, text normalization in Arabic is more difficult due to the morphological complexity of the language. Finally, the absence of sentiment-labeled corpora presents obstacles for sentiment analysis. Overall, the numerous obstacles and limitations of Arabic NLP make it difficult to implement NLP effectively in the Arabic language. In order to produce effective models for processing and comprehending language, there are still many areas that require refinement despite recent progress [19].

3 Related Works

In recent years, the development of Arabic chatbots has been a popular topic due to the demand for effective natural language processing (NLP) systems for Arabic consumers. Arabic is a complex language with numerous variations and dialects, making it difficult for machines to process and comprehend it accurately. Many researchers have proposed the use of BiLSTM (Bidirectional Long Short-Term Memory) models for Arabic chatbots in order to overcome this obstacle. BiLSTM is a deep learning technique that employs two distinct layers of LSTM (Long Short-Term Memory) networks to incorporate both forward and backward dependencies in the data, thereby enhancing language comprehension. This article will discuss the benefits of using BiLSTM for the development of Arabic chatbots, as well as the challenges that must be overcome to make such systems more effective [20,21].

Numerous studies have demonstrated that BiLSTM is effective for Natural Language Processing (NLP) tasks due to its ability to incorporate both forward and backward dependencies in the data. This enables the model to fathom the context of the text more efficiently, thereby increasing its accuracy. In addition, BiLSTM is ideally suited for the development of Arabic chatbots due to the complexity of the language's morphology, which includes two genders, three cases, and multiple verb conjugations. Traditional NLP systems may struggle to accurately process these complexities, but BiLSTM is better able to do so, resulting in enhanced performance in the development of Arabic chatbots [4].

BiLSTM has been proven to be an effective method for developing Arabic chatbots, but there are still numerous obstacles to overcome. The language variation and dialects prevalent in Arabic, for instance, make it challenging for a single model to accurately process all possible variations of the language. In addition, the paucity of large datasets containing Arabic conversations makes it challenging to train accurate models. In addition, accurately identifying and classifying user intent, as well as generating responses that sound genuine, is a significant challenge for Arabic chatbot development [22].

Due to its ability to incorporate both forward and backward dependencies in the data, BiLSTM has been demonstrated to be an effective strategy for the development of Arabic chatbots. This enhances the model's understanding of the text's context and, consequently, its accuracy. Moreover, several studies have demonstrated the effectiveness of BiLSTM for the development of Arabic chatbots, with the model attaining high levels of accuracy for both sentiment analysis and dialogue tasks. To make such systems more effective, however, there are still numerous obstacles to overcome, including the need to accurately identify and classify user intent and generate responses that sound genuine. In addition to the studies discussed above, additional studies have demonstrated the efficacy of BiLSTM for the development of Arabic chatbots. For example,

[23] used BiLSTM for natural language understanding tasks and found that the model achieved high accuracy rates for the task. Similarly, [24] used BiLSTM for machine reading tasks and discovered that the model could accurately classify text into various topics. Moreover, a study by [25] used BiLSTM for image caption generation and discovered that the model could generate accurate image captions.

In addition to the studies that have demonstrated the efficacy of BiLSTM for the development of Arabic chatbots, there are also studies that have examined potential solutions to the challenges posed by such systems. For instance, [26] proposed the use of LSTM models with Forget Gates in order to overcome the difficulty of accurately processing lengthy text sequences. Similarly, [27] proposed the use of a unified text-to-text transformer to address the difficulty of accurately generating responses that sound natural.

Overall, BiLSTM has proven to be an effective method for developing Arabic chatbots due to its ability to capture both forward and backward data dependencies. In addition, numerous studies have demonstrated the efficacy of BiLSTM for a variety of tasks, including sentiment analysis, dialogue, natural language understanding, machine reading, and image caption generation. The use of LSTM models with Forget Gates and unified text-to-text transformers are additional potential strategies for addressing the challenges posed by such systems [28,29].

4 Arabic Language

Arabic, like Hebrew and Aramaic, is a Central Semitic language [30]. It is the language of the Islamic sacred book, the Qur'an, and is spoken by about 400 million people worldwide [31], making it the fifth most widespread language. Algeria, Egypt, Iraq, Jordan, Lebanon, Morocco, Saudi Arabia, and Syria all have Arabic as their official language [32]. The Arabic alphabet is used for official as well as casual writing [33]. Furthermore, whether utilized in online communication or when writing in languages that do not use the Arabic alphabet, it is occasionally written in Latin script [30]. The language's history may be traced back to the 10th century BC, when it was spoken by ancient Arabs [(Al-Huri, n.d.)]. It is one of the oldest surviving languages and is inextricably linked to the development of Islamic civilization [(Al-Huri, n.d.)]. For millennia, it has been employed in literature, science, philosophy, and law. Furthermore, it is a necessary language in the disciplines of politics, economics, and law [34]. Arabic is being utilized in a variety of situations and is becoming an increasingly popular language to learn. The Arabic language is divided into many dialects. The Arabic language is divided into three dialects: Classical Arabic (CA), Modern Standard Arabic (MSA), and Dialect Arabic (DA).

Classical Arabic (CA)

Classical Arabic (CA) is a language of great complexity, with a vast array of vocabulary, grammar, and dialects. It is the language of the Quran and the language of Arab culture and literature. CA is the language of the Arab world, used in all areas of life, from literature and poetry to religious practices and everyday conversations. CA is based on the language of the ancient people of the Arabian Peninsula, and has been influenced by various languages over the centuries, including Aramaic, Greek, Persian, and Turkish [35]. It is written in the Arabic alphabet and is the official language of the Arab world, for example: الحمد لله بخير، تحياتي لكم , means: (Praise be to God, my regards to you). CA has many dialects and variants, with differences in pronunciation, grammar, and vocabulary. It is often divided into two main dialects, the literary dialect (used in literature and poetry) and the colloquial dialect (used in everyday conversations). These dialects are further divided into sub-dialects, which can vary significantly from region to region [36]. Learning CA is a difficult and challenging task, as it is a highly complex language with a rich vocabulary and complex grammatical rules [(Shaalan et al., 2018)]. It is often studied in universities and other educational institutions, although there are courses available to help those who wish to learn it CA is an important part of Arab culture, and is used in literature, poetry, and formal discourse. It is also used in many countries of the Arab world, as well as in non-Arab countries with strong Muslim communities. CA is an important language for understanding Arab culture and literature, and for engaging in meaningful conversations with Arab people.

Modern Standard Arabic (MSA)

Modern Standard Arabic (MSA) is the standardized and literary variety of Arabic used in formal settings, such as in the media, literature, and classrooms [37]. It is based on the classical language of the Qur'an and is the language used in almost all written material in the Arab world for example: ما هو الحال؟, means: how are you? [38] It is not a dialect and is not spoken as a native language by any group of people. Instead, it serves as an intermediary between different Arabic dialects and helps speakers of various dialects communicate with each other. MSA has evolved over time and has been influenced by modern technology and globalization [39]. In recent years, the use of MSA in the media, literature, and other forms of communication has increased, leading to a greater acceptance of the language.

In addition, recent advances in technology, such as machine translation and natural language processing, have enabled MSA to be used in more applications, such as online communication [40]. In addition, the use of MSA in the classroom has increased in recent years, with more emphasis being placed on teaching MSA at an early age [38]. Overall, MSA is a language of communication and education, serving as a bridge between different varieties of Arabic and helping speakers of different dialects to communicate with each other. It is an important part of the Arab world's culture and identity and is used in a variety of settings.

Dialect Arabic

Dialect Arabic is a variety of Arabic spoken in different countries and regions of the Middle East and North Africa. It is the native language of more than 300 million people and is used by more than 300 million more as a second language [?](Hussein Ali Alnosairee and Wayan Sartini, n.d.). Dialect Arabic is also known as "colloquial" or "vernacular" Arabic and has been described as a bridge between the formal, standard Arabic language and the many local varieties of Arabic. Dialect Arabic is distinct from Modern Standard Arabic (MSA), which is the language used for formal communication such as in the media, in the government, and in education [41]. Dialect Arabic is much more colloquial and is used in everyday conversations, often with regional variations in vocabulary and grammar. For example, the dialect spoken in Morocco, which is called "Darija," is different from the dialect spoken in Egypt, which is called "Egyptian Arabic" [42]. Despite being distinct from MSA, Dialect Arabic shares many of the same characteristics with it. For example, the dialects use the same alphabet and have similar grammar and syntax. In addition, Dialect Arabic is influenced by MSA, and borrows many of its words and expressions from it. Though Dialect Arabic is distinct from MSA, it is still considered part of the Arabic language family. It is a rich, vibrant language, and its use is growing in popularity, especially in the Middle East, North Africa, and in diaspora communities around the world [43]. As such, it is important to recognize and understand its unique features, as well as its similarities to MSA, in order to better communicate with native speakers. And these examples of dialect Arabic: Iraqi Arabic, Levantine Arabic, Maghrebi Arabic and Gulf Arabic. Iraqi Arabic:

كيفوش؟ (Keefoosh?) translated to English: How are you?

Levantine Arabic: ازاي الحال؟ (Izaay el 7aal?) translated to English: How are you?

Maghrebi Arabic: كيف حالك؟ (Kif 7aalak?) translated to English: How are you?

Gulf Arabic: كيف؟ (Kayfak?) translated to English: How are you?

5 Chatbots

Chatbot Definition

Chat is a medium of communication in which text and voice messages can be exchanged over computer networks, mobile networks, or the Internet. Chatting can be done between humans with each other, but can also involve an automated program that performs certain tasks according to given inputs, and such a program is called a chatbot. Chatbots are

also known as Chatterbots, Imbots, talkbots, chat dialogue systems, and conversational agents [44]. Chatbots are one of the remarkable applications that have recently proven their efficiency and effectiveness. They are types of a simulation program that analyzes and processes human conversations, either written or spoken, and interacts with end-users through a digital device. They have significantly evolved over the past few years. They have been adopted in various fields and sectors, whether public or private. With chatbots, user's requests are responded to, analyzed, and based on that, decisions can also be made. Chatbots have the ability to learn from dialogues and conversations with users [45]. Chatbot systems have been developed to become a virtual assistant in answering questions and entertaining people and are used as an assistant in smart homes [46] in a way similar to human work in using natural language and trying to understand what users need [47] through the use of artificial intelligence and machine learning, taking into account three key aspects: perception, learning, and planning [48].

Chatbot Definition

Education

Chatbots are increasingly being used in higher education institutions to support other e-learning practices and for their role in assisting students to obtain information and provide educational content [49]. Conversational robots help a lot in the educational process and learning as they help students in retaining information and repeating lessons missed by the student and also assisting the student with the problems he/she faces, whether they are administrative, such as registration, exam schedules, grades, or academic ones, such as answering questions related to the presented educational curriculum.

Government & Public Sectors

The adoption of a chatbot in the public sector contributes to providing easy to access services to users. One challenge that might face such an adoption is that chatbots may collect user data to build on top of the knowledge base and further improve performance. This process is important and requires input from government experts, given their knowledge in the field, to ensure data validity. However such data may become prone to automatic exploitation. Another challenge that might impede the adoption of chatbots in public or government sectors is the ethical and social barriers due to the lack of confidence of citizens in machines, as they think that they will replace employees one day. With the increase in the use of robots in many areas of our life, technological services help construct a modern future government that can achieve its services with higher quality and efficiency, thus making it easier to access and used by users [50].

Healthcare

Chatbots provide patients in the healthcare field with information about health, products and services related to them as patients, diagnose patients and based on symptoms appropriate treatment is suggested. Robots have been developed to check disease symptoms and suggest appropriate treatment, such as BuoyHealth; an AI-powered web-based symptom checker [Buoy Health: Check Symptoms & Find the Right Care]. Customer service The development guided by AI and the development of communication techniques constantly communicating between people and their interaction with each other, and for companies, the development of electronic commerce, which led to the solution of many problems facing these companies, especially with the sale and application of products, the most important of which is customer service where the business employee took a long time to answer or respond to customers, and in some cases, the answer is not clear enough or irrelevant [51]. Industry In the banking sector and with technological development, many companies and banks use chatbots to serve customers, such as helping them pay bills, provide their account data and balances, facilitate the activation of cards, and also work to collect customer opinions and comments. America's Erika and bank of Australia's Ceba is example of such chat robots [13].

Robotics

The natural language interface is the most important area in conversation robots and physical robots. Many natural language applications have been developed, such as the application and development of a natural language interface for vision based robot instructions [52].

6 Methodology

The suggested function of our chatbot is a question answering Arabic chatbot. To serve the education field using a neural network as a popular and valuable model for classification, grouping, pattern recognition, and prediction across various fields. The Bi-LSTM technique was used in this research. The phases of this chatbot are indicating in the below Fig. 1.

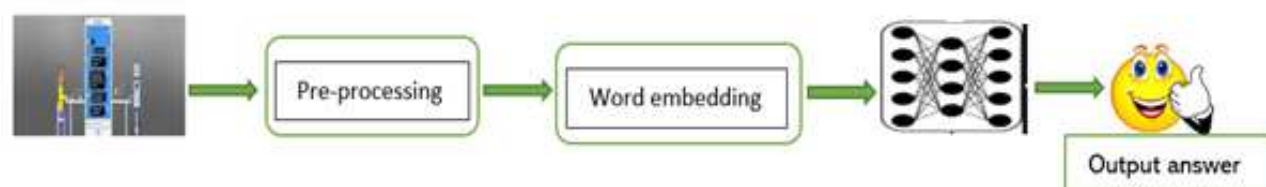

Fig. 1: Chatbot step diagram

Data Collection

Build a chatbot system in NLP requires a large amount of data. Data is essential to train the chatbot model as it come in the form of conversation dialogue and used as base knowledge for the chatbot. We collect such data from educational websites, mainly the Ministry of Education of the UAE (<https://www.moe.gov.ae>), the dataset consisted of 300,000 words in Arabic. All the collected questions related to education would be to build the dictionary. Furthermore, we categorized the questions using three intents (tag, pattern, and response) stored in the JSON structure. Each tag represents the main information to be asked about. Each tag has a group of patterns or forms in which a question can be asked. Also, each tag has a dedicated response to be given to the users if any of the associated questions was asked [18].

Preprocessing

The dataset was preprocessed using Python and the Natural Language Toolkit (NLTK). This includes cleaning text, tokenizing words, padding sequences, and creating dictionaries. Tokenizing involves splitting the text into individual words, while padding involves adding extra words to a sequence to make it a fixed length. Additionally, a dictionary was created that mapped words to their numerical equivalents, which could then be used by the model. Other preprocessing steps might also have been necessary, such as removing stop words or using stemming [53].

Model Architecture

We used BiLSTM architecture with four layers. The input layer consists of the preprocessed data. The first two layers are bidirectional LSTM layers. The third layer is a fully connected layer. The output layer is a softmax layer. And the five layer BiLSTM architecture included an embedding layer as the input layer, two bidirectional LSTM layers, a dropout layer, a max pooling layer, and a softmax layer as the output layer, as represented in Fig. 2. The embedding layer was used to represent the words in the chatbot's vocabulary as numerical vectors, which were fed into the two bidirectional LSTM layers to capture the temporal dependencies between words. The convolutional layer was used to detect patterns in the sequence of words, while the max pooling layer was used to reduce the dimensionality of the input and extract the most important features. Finally, the softmax layer was used to predict the most likely response based on the input [54].

Model training

To train the model, we employed a three-stage training process using back propagation and the Adam optimizer. We used grid search to tune the hyper parameters of the model we used a learning rate of 0.001, a batch size of 64, and a dropout rate of 0.2. The model was trained for 200 epochs. Table 1, presents the parameters configuration that used in the model. Table 1 is a Default BiLSTM model parameters configuration [55].

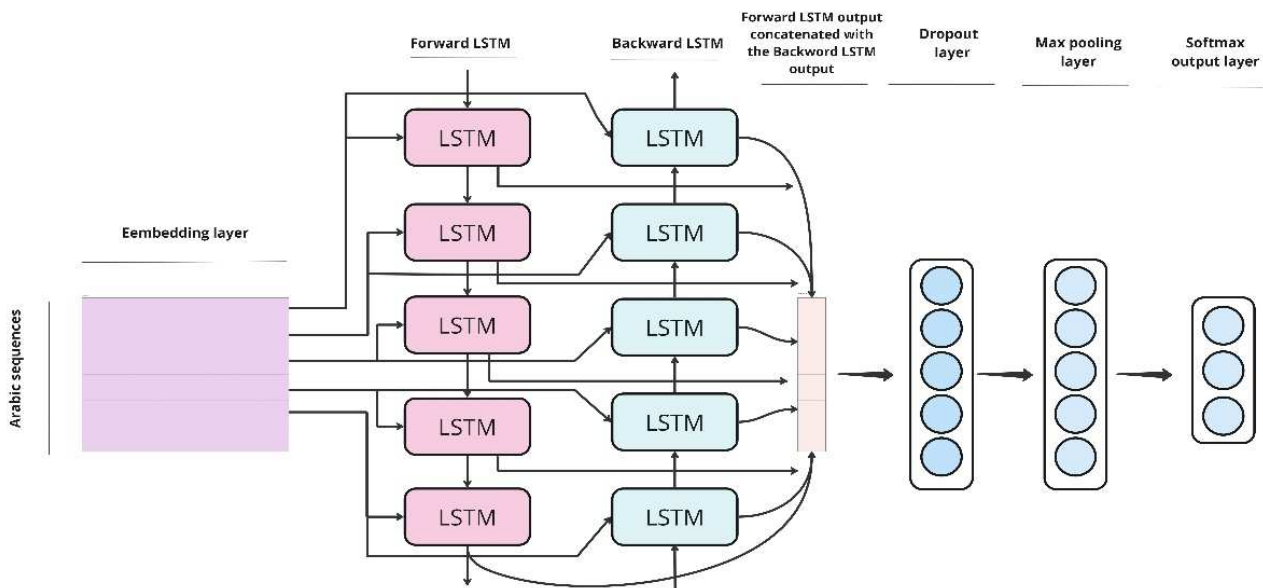

Fig. 2: Our Proposed BiLSTM Model.

Table 1: Hyper-parameters and their values.

Hyper-parameter	Value
Learning rate	0.001
Batch size	64
Dropout rate	0.2
Number of epochs	200

Model evaluation

We evaluated the model using accuracy which is computed by dividing the number of correctly classified examples by the total number of examples [56]. Accuracy = Number of Correctly Classified Examples/ Total Number of Examples [56]. And F1-score which is computed by taking the harmonic mean of precision and recall [41]. F1-score = $2 \times (\text{Precision} \times \text{Recall}) / (\text{Precision} + \text{Recall})$ [41]. In addition to BLEU score which is a metric used to measure the quality of a machine translation system [57].

$$\text{BLEU Score} = (1/n) \sum_{i=1}^n P_i \cdot \text{BP}_i \quad [57]$$

Where n is the number of n-grams, P_i is the precision of the translated text for each n-gram, and BP_i is a brevity penalty based on how many words are in the translated text compared to the reference text.

We obtained an accuracy of 85.2%, an F1-score of 0.899 and a BLEU score of 0.842. These results demonstrate the effectiveness of the BiLSTM model for Arabic chatbot applications.

Table 2, shows the comparison of the results between the four layer BiLSTM architecture and the five layer BiLSTM architecture showed that the five layers' architecture was more accurate and had higher F1-score and BLEU scores than the four layer architecture. The five layer architecture achieved an accuracy of 85.2%, an F1-score of 0.899 and a BLEU score of 0.842, while the four layer architecture achieved an accuracy of 80.8%, an F1-score of 0.836, and a BLEU score of 0.819. This indicates that the five layer architecture is better suited for Arabic chatbot applications.

Table 2: BiLSTM best model results.

Model Configuration	Accuracy (%)	F1-score (%)	BLEU score
BiLSTM(4Layers)	80.8	0.836	0.819
BiLSTM(5Layers)	85.2	0.899	0.842

7 Conclusion

Chatbot is intelligent systems that can communicate with humans utilizing human language processing (NLP) while also giving responses. It recognizes the user input by access information to provide a predefined acknowledgment. We will focus on Bi-LSTM because its seq2seq methodology so it can take short and long sentence or text and analyse them and read them as a sequence data. Arabic chatbots equipped with BiLSTM networks have the potential to revolutionize the way Arabic speakers interact with machines. By leveraging the effectiveness of BiLSTM networks, these chatbots can be trained to understand and generate text in Arabic, providing an intuitive user experience for Arabic speakers. This paper has discussed the potential applications of BiLSTM networks in the context of Arabic chatbot development, and provided some examples of current Arabic chatbots that are equipped with BiLSTM networks. We Aims to facilitate to the users, students, parents, teachers and principals to get the full information from ministry of education without need to visit the ministry and without send emails to be available 24/7. To reduce the time of searching on internet. And support the Arabic language, were there are many research publish approved and methods in English language and scarcity of Arabic research and many challenges faced the Arabic NLP. As future work, will continue with project steps to get results and evaluate it and continue with the study plan to implement and deploy dialect Arabic chatbot using neural network.

Conflict of Interest

The authors declare that there is no conflict regarding the publication of this paper.

References

- [1] M. M. Van Pinxteren, M. Pluymaekers and J. G. Lemmink, Human-like communication in conversational agents: a literature review and research agenda, *Journal of Service Management* **31**(2) (2020) 203–225.
- [2] A. Landim, A. Pereira, T. Vieira, E. de B. Costa, J. Moura, V. Wanick and E. Bazaki, Chatbot design approaches for fashion e-commerce: an interdisciplinary review, *International Journal of Fashion Design, Technology and Education* **15**(2) (2022) 200–210.
- [3] M. Adam, M. Wessel and A. Benlian, Ai-based chatbots in customer service and their effects on user compliance, *Electronic Markets* **31**(2) (2021) 427–445.
- [4] B. A. Alazzam, M. Alkhatib and K. Shaalan, Artificial intelligence chatbots: A survey of classical versus deep machine learning techniques (2023).
- [5] I. Goodfellow, Y. Bengio and A. Courville, *Deep learning* (MIT press, 2016).
- [6] Y. Bengio, Y. Lecun and G. Hinton, Deep learning for ai, *Communications of the ACM* **64**(7) (2021) 58–65.
- [7] Y. LeCun, Y. Bengio and G. Hinton, Deep learning, *nature* **521**(7553) (2015) 436–444.
- [8] W. Li, K. Xu, J. Qi and X. Ding, A natural language processing method of chinese instruction for multi-legged manipulating robot, in *2018 IEEE International Conference on Robotics and Biomimetics (ROBIO)*, IEEE2018, pp. 2171–2176.
- [9] R. Zhang, Q. Lv, J. Li, J. Bao, T. Liu and S. Liu, A reinforcement learning method for human-robot collaboration in assembly tasks, *Robotics and Computer-Integrated Manufacturing* **73** (2022) p. 102227.
- [10] J. Gao, M. Galley and L. Li, Neural approaches to conversational ai, in *The 41st International ACM SIGIR Conference on Research & Development in Information Retrieval*, 2018, pp. 1371–1374.
- [11] A. Ankit, I. Chakraborty, A. Agrawal, M. Ali and K. Roy, Circuits and architectures for in-memory computing-based machine learning accelerators, *IEEE Micro* **40**(6) (2020) 8–22.
- [12] A. Krizhevsky, I. Sutskever and G. E. Hinton, Imagenet classification with deep convolutional neural networks, *Communications of the ACM* **60**(6) (2017) 84–90.
- [13] K. Kerasovitis, Artificial unintelligence: how computers misunderstand the world/the message is murder: substrates of computational capital: by meredith broussard, cambridge and london, mit press, 2018, 248 pp.,£ 19.95 (hardback), isbn 9780262038003/by jonathan beller, london, pluto press, 2018, 224 pp.,£ 75.00 (hardback), isbn 9780745337319,£ 18.99 (paperback), isbn 9780745337302, *Information, Communication & Society* **22**(10) (2019) 1514–1516.
- [14] G. Hinton, L. Deng, D. Yu, G. E. Dahl, A.-r. Mohamed, N. Jaitly, A. Senior, V. Vanhoucke, P. Nguyen, T. N. Sainath *et al.*, Deep neural networks for acoustic modeling in speech recognition: The shared views of four research groups, *IEEE Signal processing magazine* **29**(6) (2012) 82–97.
- [15] Z. C. Lipton, D. C. Kale, C. Elkan and R. Wetzel, Learning to diagnose with lstm recurrent neural networks, *arXiv preprint arXiv:1511.03677* (2015).
- [16] G. Wang, W. Li, M. A. Zuluaga, R. Pratt, P. A. Patel, M. Aertsen, T. Doel, A. L. David, J. Deprest, S. Ourselin *et al.*, Interactive medical image segmentation using deep learning with image-specific fine tuning, *IEEE transactions on medical imaging* **37**(7) (2018) 1562–1573.
- [17] J. Zhao, Corporate financial risk prediction based on embedded system and deep learning, *Microprocessors and Microsystems* (2020) p. 103405.

- [18] N. Bhartiya, N. Jangid, S. Jannu, P. Shukla and R. Chapaneri, Artificial neural network based university chatbot system, in *2019 IEEE Bombay Section Signature Conference (IBSSC)*, IEEEJuly 2019, pp. 1–6.
- [19] K. Shaalan, S. Siddiqui, M. Alkhatib and A. Abdel Monem, Challenges in arabic natural language processing, in *Computational linguistics, speech and image processing for Arabic language*, (Springer, 2019) pp. 59–83.
- [20] D. Liang and Y. Zhang, Ac-blstm: asymmetric convolutional bidirectional lstm networks for text classification, *arXiv preprint arXiv:1611.01884* (2016).
- [21] I. H. Sarker, Deep learning: a comprehensive overview on techniques, taxonomy, applications and research directions, *SN Computer Science* **2**(6) (2021) p. 420.
- [22] E. S. AlHagbani and M. B. Khan, Challenges facing the development of the arabic chatbot, in *First International Workshop on Pattern Recognition*, **10011**, SPIE2016, pp. 192–199.
- [23] A. A. Sharfuddin, M. N. Tihami and M. S. Islam, A deep recurrent neural network with bilstm model for sentiment classification, in *2018 International conference on Bangla speech and language processing (ICBSLP)*, IEEE2018, pp. 1–4.
- [24] G. Liu and J. Guo, Bidirectional lstm with attention mechanism and convolutional layer for text classification, *Neurocomputing* **337** (2019) 325–338.
- [25] V. Chaithra, D. C. Rao and N. Jagadisha, Image caption generator using deep learning, *International Journal of Engineering Applied Sciences and Technology* **7**(2) (2022) 289–293.
- [26] F. A. Gers, J. Schmidhuber and F. Cummins, Continual prediction using lstm with forget gates, in *Neural Nets WIRN Vietri-99: Proceedings of the 11th Italian Workshop on Neural Nets, Vietri Sul Mare, Salerno, Italy, 20–22 May 1999*, Springer1999, pp. 133–138.
- [27] C. Raffel, N. Shazeer, A. Roberts, K. Lee, S. Narang, M. Matena, Y. Zhou, W. Li and P. J. Liu, Exploring the limits of transfer learning with a unified text-to-text transformer, *The Journal of Machine Learning Research* **21**(1) (2020) 5485–5551.
- [28] E. M. Nagoudi, A. Elmadany and M. Abdul-Mageed, Arat5: Text-to-text transformers for arabic language understanding and generation, *arXiv preprint* (2021).
- [29] D. A. Aljohany, H. M. Al-Barhamtoshy and F. A. Abukhodair, Arabic machine translation (arnt) based on lstm with attention mechanism architecture, in *2022 20th International Conference on Language Engineering (ESOLEC)*, **20**, IEEEOctober 2022, pp. 78–83.
- [30] B. Pietrzak *et al.*, Rhotic phonemes in semitic languages—the case of classical arabic and biblical hebrew, *Lublin Studies in Modern Languages and Literature* **42**(1) (2018) 33–48.
- [31] M. H. Bashir, A. M. Azmi, H. Nawaz, W. Zaghouni, M. Diab, A. Al-Fuqaha and J. Qadir, Arabic natural language processing for qur’anic research: a systematic review, *Artificial Intelligence Review* (2022) 1–54.
- [32] N. M. Aloudah, Qualitative research in the arabic language. when should translations to english occur? a literature review, *Exploratory Research in Clinical and Social Pharmacy* (2022) p. 100153.
- [33] G. A. Abandah and M. Z. Khedher, Analysis of handwritten arabic letters using selected feature extraction techniques, *International Journal of Computer Processing of Languages* **22**(01) (2009) 49–73.
- [34] L. Harb, Arabic literary theory, in *Oxford Research Encyclopedia of Literature*, 2020
- [35] A. A. Khrisat and Z. A. Alharthy, Arabic dialects and classical arabic language, *Advances in Social Sciences Research Journal* **2**(3) (2015) 254–260.
- [36] R. Khalaila, Translation of questionnaires into arabic in cross-cultural research: techniques and equivalence issues, *Journal of Transcultural Nursing* **24**(4) (2013) 363–370.
- [37] A. Aziz, Al-arabiyyah, le français, and the soul of algeria: The language tango between arabic and french in algerian education policy and defining post-colonial algerian national identity (2015).
- [38] A. Gebril and H. Taha-Thomure, Assessing arabic, *The Companion to Language Assessment* (2014) 1781–1789.
- [39] I. Guellil, H. Saâdane, F. Azouaou, B. Gueni and D. Nouvel, Arabic natural language processing: An overview, *Journal of King Saud University-Computer and Information Sciences* **33**(5) (2021) 497–507.
- [40] K. Jiang and X. Lu, Natural language processing and its applications in machine translation: A diachronic review, in *2020 IEEE 3rd International Conference of Safe Production and Informatization (IICSPI)*, IEEE2020, pp. 210–214.
- [41] S. U. Hassan, J. Ahamed and K. Ahmad, Analytics of machine learning-based algorithms for text classification, *Sustainable Operations and Computers* **3** (2022) 238–248.
- [42] S. Bettega, M. Roberta *et al.*, The classification of arabic dialects: Traditional approaches, new proposals, and methodological problems (2022).
- [43] N. Ibrahim, Classical standard arabic versus modern standard arabic: A theoretical framework, *Journal of the Faculty of Arts and Humanities, Suez Canal University* **5**(43) (2022) 76–150.
- [44] E. Adamopoulou and L. Moussiades, An overview of chatbot technology, in *Artificial Intelligence Applications and Innovations: 16th IFIP WG 12.5 International Conference, AIAI 2020, Neos Marmaras, Greece, June 5–7, 2020, Proceedings, Part II*, **16**, (Springer International Publishing, 2020), pp. 373–383.
- [45] M. Mohasses, How ai-chatbots can make dubai smarter?, in *2019 Amity International Conference on Artificial Intelligence (AICAI)*, IEEEFebruary 2019, pp. 439–446.
- [46] N. N. Khin and K. M. Soe, Question answering based university chatbot using sequence to sequence model, in *2020 23rd Conference of the Oriental COCOSDA International Committee for the Co-ordination and Standardisation of Speech Databases and Assessment Techniques (O-COCOSDA)*, IEEENovember 2020, pp. 55–59.

- [47] H. Yamaguchi, M. Mozgovoy and A. Danielewicz-Betz, A chatbot based on aiml rules extracted from twitter dialogues, in *FedCSIS (Communication Papers)*, IEEE2018, pp. 37–42.
- [48] O. E. Oduntan and O. J. Adegboye, Enhancing communication technology through an intelligent chatbot system, *International Journal of Innovative Technology and Exploring Engineering* **9**(6S) (2020) 117–120.
- [49] F. Colace, M. De Santo, M. Lombardi, F. Pascale, A. Pietrosanto and S. Lemma, Chatbot for e-learning: A case of study, *International Journal of Mechanical Engineering and Robotics Research* **7**(5) (2018) 528–533.
- [50] C. Van Noordt and G. Misuraca, New wine in old bottles: Chatbots in government: Exploring the transformative impact of chatbots in public service delivery, in *Electronic Participation: 11th IFIP WG 8.5 International Conference, ePart 2019, San Benedetto Del Tronto, Italy, September 2–4, 2019, Proceedings*, **11**, Springer International Publishing2019, pp. 49–59.
- [51] F. Johannsen, S. Leist, D. Konadl and M. Basche, Comparison of commercial chatbot solutions for supporting customer interaction, *Procedia CIRP* **72** (2018) 994–999.
- [52] S. Lauria, G. Bugmann, T. Kyriacou and E. Klein, Mobile robot programming using natural language, *Robotics and Autonomous Systems* **38**(3-4) (2002) 171–181.
- [53] F. Millstein, *Natural language processing with python: natural language processing using NLTK* (Frank Millstein, 2020).
- [54] J. Tong, Z. Wang and X. Rui, A multimodel-based deep learning framework for short text multiclass classification with the imbalanced and extremely small data set, *Computational Intelligence and Neuroscience* **2022** (October 6 2022).
- [55] S.-Y. Yi, R. Goel, C. Khatri, A. Cervone, T.-H. Chung, B. Hedayatnia, A. Venkatesh, R. Gabriel and D. Hakkani-Tur, Towards coherent and engaging spoken dialog response generation using automatic conversation evaluators, *arXiv preprint arXiv:1904.13015* (2019).
- [56] T. Su, H. Sun, J. Zhu, S. Wang and Y. Li, Bat: Deep learning methods on network intrusion detection using nsl-kdd dataset, *IEEE Access* **8** (2020) 29575–29585.
- [57] S. Edunov, M. Ott, M. Ranzato and M. Auli, On the evaluation of machine translation systems trained with back-translation, *arXiv preprint arXiv:1908.05204* (2019).
-