

# Cluster-Based Energy Hop Count Analysis for Dynamic Route Selection in Mobile Wireless Sensor Network

M. Sudha<sup>1,\*</sup> and J. Sundararajan<sup>2</sup>

<sup>1</sup> Department of Electronics and Communication Engineering, Paavai Engineering College, Namakkal, Tamilnadu, 637 018, India

<sup>2</sup> Pava College of Technology, Namakkal, Tamilnadu, 637 018, India

Received: 2 Mar. 2019, Revised: 2 Apr. 2019, Accepted: 26 Apr. 2019

Published online: 1 Jul. 2019

**Abstract:** The routing in Mobile Wireless Sensor Networks (MWSN) has been considered in a limited article which influences the quality of service of MWSN. The prior methodologies consider the traffic-based routing which screens just the blockage quantity in the routes accessible. In true conditions, considering the energy parameters in the hops of routes would not create effective execution. To enhance the service in mobile wireless sensor network, a productive zone-based Cluster Energy Hop Based Dynamic Route Selection (CEH-DRS) for the most extraordinary element of mobile wireless sensor networks is that the nodes can perform both the gathering and transmission of packets, additionally, they support routing the information packages arise from different source nodes to achieve different intentions. The CEH routing scheming to observe the traffic in various location of the network and when the routes are observed, they are part as indicated by the local parameters. Based on the traffic proportion, energy and hop-record delicate elements of the routes, the strategy plays out a dynamic determination of sending route-based on a cluster. The strategy chooses the route through the number of parameters considered, and is based on that a productive route has been chosen in such an approach to keep up the throughput and increase the lifetime of the network.

**Keywords:** Cluster, routing, Energy, Route selection, Wireless network, Hop count

## 1 Introduction

Routing is the procedure of data trade starting with one host then onto the next in a network. Routing is the component of sending a parcel to its goal, utilizing the most effective way. In a wireless network with shared assets, where various senders go after connection transfer speed, it is important to modify the data rate utilized by every sender altogether not to over-burden the network. Bundles that touch base at a switch and can't be sent are dropped; subsequently, an unreasonable number of parcels landing at a network bottleneck prompt numerous parcel drops. These dropped bundles may as of now have voyage far in the network, and in this manner expended noteworthy assets.

Furthermore, the lost parcels frequently trigger retransmission, which implies that considerably more bundles are sent into the network. Hence network congestion can seriously break down the network throughput. On the off chance that no proper congestion control is played out, this can prompt a congestion fall in the network, where no data is effectively conveyed.

Another course disclosure is required just when every one of these ways come up short. To monitor various courses, the routing section for every goal contains a rundown of the following hops alongside the relating hop tallies.

All the following hops have a similar arrangement number. For every goal, a node keeps up the publicized hop check, which is characterized as the greatest hop mean every one of the ways. This is the hop check utilized for sending course ads of the goal. Each copy course ad got by a node characterizes an elective way to the goal.

To guarantee circle opportunity, a node just acknowledges a substitute way to the goal, in the event that it has a hop tally lower than the hop tally promoted for that goal. In these sorts of networks, a large portion of the nodes relies upon different nodes to forward the parcels. There are some extraordinary nodes, which give away just between specific sets of nodes. In connection to the nodes that exhaust their battery and quit working, there is a probability that a few nodes can't convey any longer.

\* Corresponding author e-mail: [sudhauphd@mail.com](mailto:sudhauphd@mail.com)

The courses that are enhanced are decided for multipath data transmission from a source to a goal. On the off chance that another source endeavors to transmit data through the course which is as of now used with a source, at that point, it is expected that congestion is probably going to happen. At that point, the transmission of data over the course is considered as over-burden and transmission is ceased.

The node transmits the over-burden movement esteem as a criticism to the comparing source and the source transmits the over-burdensome portion of the activity through the other existing ways. The associations between the network nodes are wireless, and the correspondence medium is communicated. The wireless association furnishes the nodes with the opportunity to move, so they may meet up as required and frame a network, not really with any help from the link associations.

The route disclosure system they have produced for the portable routing spine progressively conveys the activity inside the network, as indicated by the present network movement levels and the nodes handling loads [1]. They have demonstrated that their approach enhances the network throughput and packet conveyance proportion by coordinating movement through modest congested districts of the network that are wealthy in assets. Here, sight and sound activity is considered as high-need movement, and its routing is completed over the gently-loaded connections, which are chosen as another option to join holding heavier loads [2, 3].

Additionally, the assets are shared among the high- and low- (typical activity) need movement. The daintily-loaded way is utilized by typical activity in the absence of sight and sound movement [4]. Additionally, the node store contains various courses to the goal and this is exceptionally advantageous for low-versatility networks. It isn't powerful for expansive networks, i.e., the entirety of the overhead in every packet keeps on increasing when the network distance across is expanded [5].

The cluster-based methodologies may endure due to issues of the clustering procedure, for example, the node focus issue, low unwavering quality for data correspondence because of less thought of the node correspondence [6, 7], and expanded data correspondence overhead while building clusters. The clusters self rule and proactively screen congestion inside its confined degree [8].

The present approach enhances the responsiveness of the framework when contrasted with end-to-end methods. In the wake of assessing the movement rate along a way, the sending rate of the source nodes is adjusted in the same way [9, 10]. Therefore, this convention envisions the infusion of dynamic streams in the network and proactively adjusts the rate while sitting tight for congestion input. A portable specialist-based congestion control AODV routing convention is proposed, to dodge congestion in the ad-hoc network. Some portable operators are gathered in an ad-hoc network, which

conveys the routing data and the nodes congestion status [10, 11].

At the point when the versatile specialist travels through the network, it can choose a less-loaded neighbor node as its next hop and it refreshes the routing table as indicated by the node's congestion status [12, 13]. With the help of the versatile specialists, the nodes can get the dynamic network topology in time. The convention looks through the whole network to find the goal. This looking procedure is an expensive activity, and it causes the delay in the packet being conveyed [14].

Because of successive topology changes and absence of convenient refreshing components all the time, the data put away as a reserve may become obsolete. Consequently, the execution may degrade [15, 16]. This area shows a portion of the multipath conventions, which enhance the course revelation and course upkeep, however, the load adjusting and congestion control plans are not incorporated. This empowers them to trade data and interface them with the routing framework through wireless passages accessible along the roads [17, 18].

This approach addresses the issues identified by making and keeping up a crossbreed network made out of both wired and wireless ad-hoc networks [19]. The framework proposes a system to enable clients to trade messages between one or different nodes exhibited in the city road network and to furnish them with routing data keeping in mind the end goal to evade automobile overloads or stay away from perilous conditions [20].

## 2 Materials and Methods

The execution of the network relies upon various measurements like throughput, idleness, and routing of packet conveyed. All these three components are interconnected and there exist different traffic dangers for the packets which go through the network channels. Current challengers perform different traffic like adjustment, deceiving, sink openings and some more. To insure the network packets from these events, the academics have proposed diverse methodologies with various characteristics of packets. Still, there are numerous issues which do not consider to defeat the issue of network dangers. For instance, the routing approaches utilize highlights like payload, ttl, jump tally, bounce addresses, etc.

Fig. 1 shows the data communication between the numbers of cluster in network, it means that if any node failure or congestion occur means to choose dynamically other intermediate node for data transfer. Correspondingly there are numerous cases which do not consider to perform cluster-based routing. This paper goes for performing distinctive structures like distinguishing route, dynamic route choice, stream construct guess thus with respect to. The proposed strategy utilizes different highlights as like prior methodologies yet in the various path like if there should be an occurrence of routing

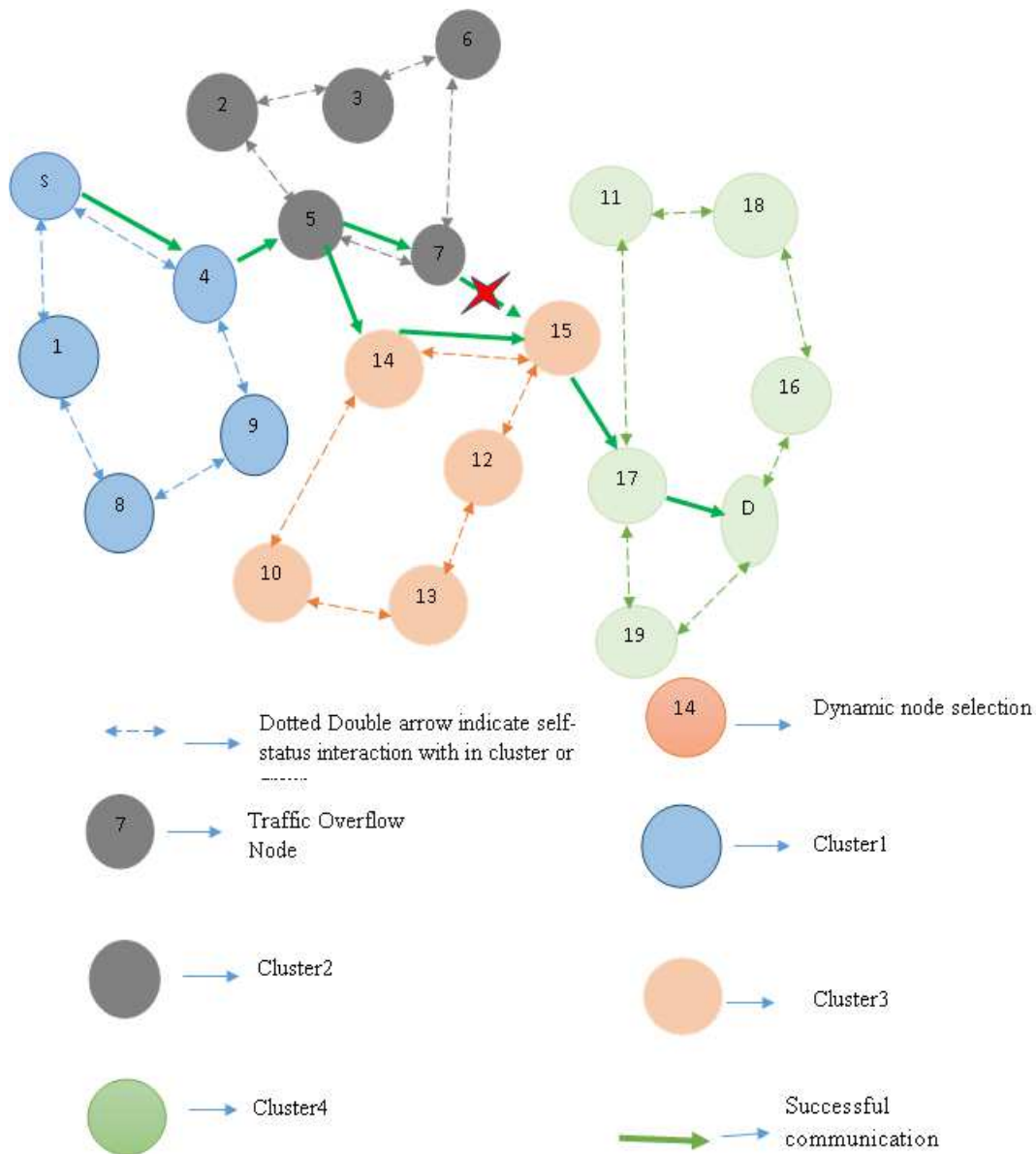

**Fig. 1:** Work flow of proposed approach

approach shows in Fig. 2, we recognize the example of packet traversal and with the assistance of service get to history the regular nodes introduce in the traversal route is illustrious. The proposed Cluster Energy Hop Based Dynamic Route Selection (CEH-DRS) approach has different stages like node extraction, cluster head detection, node energy analysis and dynamic route selection. Each stage has the distinctive degree and we talk about them in detail in this area.

### 2.1 Node Feature Extraction

The node information packet got at the network interface port deals with at the element extraction stage. The packet is changed over into IP Packet and its highlights like node id, thickness points of interest, neighbor address, neighbor details, time to leave esteems are removed. From the extracted esteems we change over them into a vector by adding those highlights and routing to the network next examination stage.

#### Algorithm 1

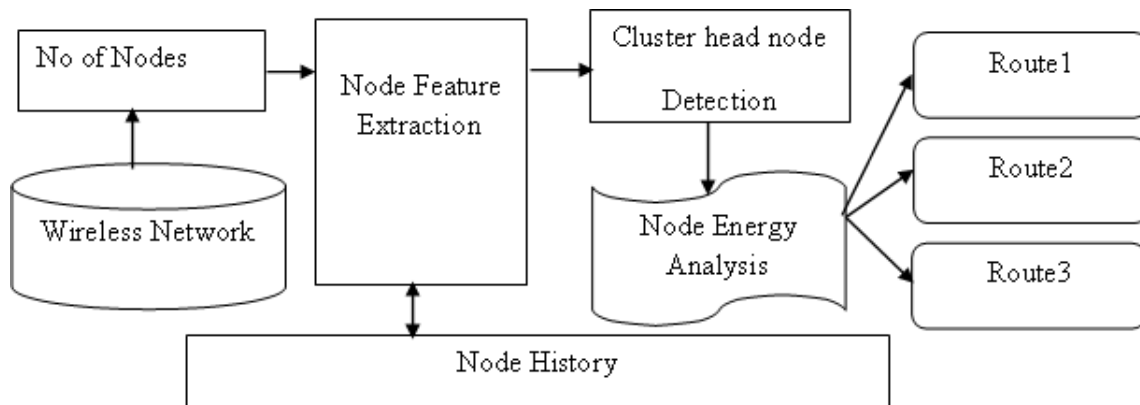

Fig. 2: Basic architecture

**Start**

To get no of nodes.

Extract node id NID of network Ni.

$$NID = \int Nodes \in Ni$$

Extract source address Sa of Ni.

$$Sa = \int Ni \in NID$$

Extract density of node Dn from Sa

$$Dn = \int Dn \in Sa$$

Extract neighbor node addresses

$$Nna = \int \sum_N i^n source\ address \in network\ size$$

Extract neighbor node details from Nna

$$NnD = \int Ni(Nna)$$

Extract time to live details from NnD

$$TTL D = \int NnD \in Noof\ packets(Nna)$$

Construct all features CAF.

$$CAF = \{NID, Sa, Dn, Nna, NnD, TTL D\}.$$

**Stop.**

The above design removes the highlights of the packet being obtained and it separates the source and goal address, source and goal port, density, ttl esteem and next jump of the network.

## 2.2 Cluster Head Detection

We perform discovering proof of cluster head which presents more successive traffic with the assistance of exchanging the data between nodes of any network. For any packet got through the network, the highlights are removed and the separated highlights have neighbor addresses through which the packet is navigated. From the historical backdrop of prior packets being got and with the present element vector an arrangement of extraordinary traversal way are recognized. From the unique arrangement of routing, we recognize set of nodes which happens all the more much of the time and regular nodes through which the packets being crossed. Additionally, with the support of network topology, we distinguish the set of an accessible route to achieve the service point. By utilizing both the accessible route, one

of a kind of traversal route and current host succession, the node is identified as a cluster head or not.

**Algorithm 2****Start**

Initialize number of nodes InN.

Identify the all features CAF.

If  $CAF \ni$  Node details

Then

Compute all the node details in network

End

$$ND = \int \frac{Nodes(\sum CAF)}{\text{Density of network}}$$

Compute neighbor node details

$$NnD = \int Ni(Nna) * ND$$

If  $NnD >$  Network density, then

If  $Node(size) >$  no of packets

then

Choose the node and produce the login history and access history.

$$Node = \sum \frac{Size(node)}{\text{Density of network}}$$

End

Else

Allow the packet.

End.

**Stop.**

The above-discussed algorithm identifies the cluster head in the network and produces log in the contact history.

## 2.3 Node Energy Analysis and Dynamic Route Selection

It performs dynamic route determination which is based on node energy. For any route request for delivered by the source, it needs to achieve the goal on time with limited flexibility. Here we utilize this property of network packets to discover them whether the packet is altered or imitated by any of the cluster nodes displayed in transition. Also, the traversal time of every packet and

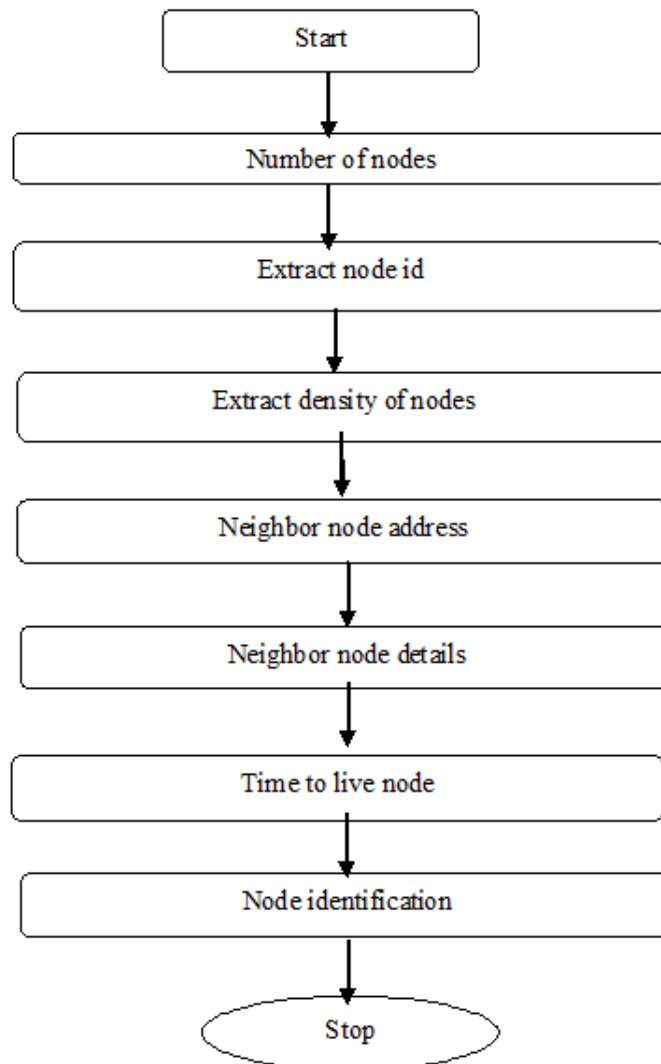

**Fig. 3:** Flow chart of node extraction

number of hop traveled and normal suspension happened at the network and current traffic condition to predict the packet creation.

Fig. 5 shows the flowchart of the energy-based route selection approach and it shows each step of the proposed method in the network.

**Algorithm 3**

**Start**

Identify the no of cluster head in network

$$Ch = \sum CAF \times Network\ size$$

Calculate normal payload

$$CnP = \frac{\sum Neighbour\ node(NID, Location)}{size(network)}$$

Compute route  $Ri = \sum CnP(ChN)$

if Route = free

    Perform data transmission.

    Perform flow of next hop.

End.

**Stop.**

The above-discussed algorithm performs energy-based dynamic route selection approach in performing cluster head-based packet transmission in the network.

**3 Results and Discussion**

Proposed approaches are run and simulated using network simulator, then the all code is created into Tcl script. Based on the simulated result the given output and simulated results are shown. In our proposed approach Cluster Energy Hop Based Dynamic Route Selection

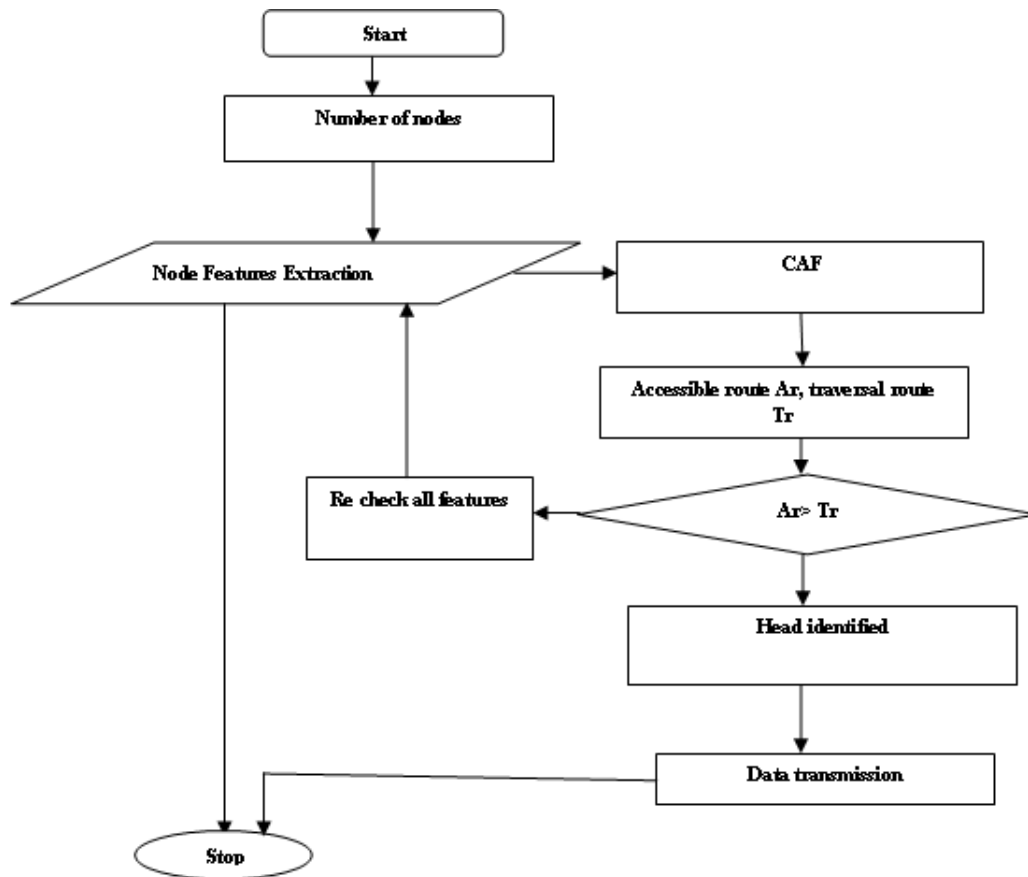

Fig. 4: Flow chart of the cluster head selection

(CEH-DRS) is compared with four existing algorithms, which are Optimized Route Cache Protocol-AODV (ORC-AODV), Fuzzy and Bee Colony Optimization (FBCO), Selectively Turning ON/OFF the Sensors (STOS) and Hidden Markov Model (HMM).

Table 1: Similar examination

No.of nodes	ORC-AODV in %	FBCO in %	STOS in %	HMM in %	CEH-DRS in %
20	10	12	19	22	29
40	19	21	35	39	32
60	35	39	45	49	52
80	37	42	61	69	72
100	42	56	72	82	94

### 3.1 Packet delivery ratio Impact

It's used to survey idea through the framework. It represents extent among all packets in the network. In source to destination how many packets are sent in particular time, its called delivery ratio.

$$PDR = \frac{\text{Packets received}}{\text{Produced parcels}} \times 100$$

Fig. 6 maintain the result of the planned work with the simulated output. CEH-DRS has a normal increment in PDR of 12% through the existing.

### 3.2 Examination of End-to-end Delay

End-to-end delay is nothing but between the times to take from one packet to another packet in a network. That time to take all kind of parameter in data transmission.

Table 2 exhibitions the conclusion to termination defer examination of the planned framework with the current frameworks. Fig. 7 exhibits the E2E examination of the prearranged schemes with the present structures. Since Fig. 7 shows that CEH-DRS consumes lessened this one conclusion of the packet transmission.

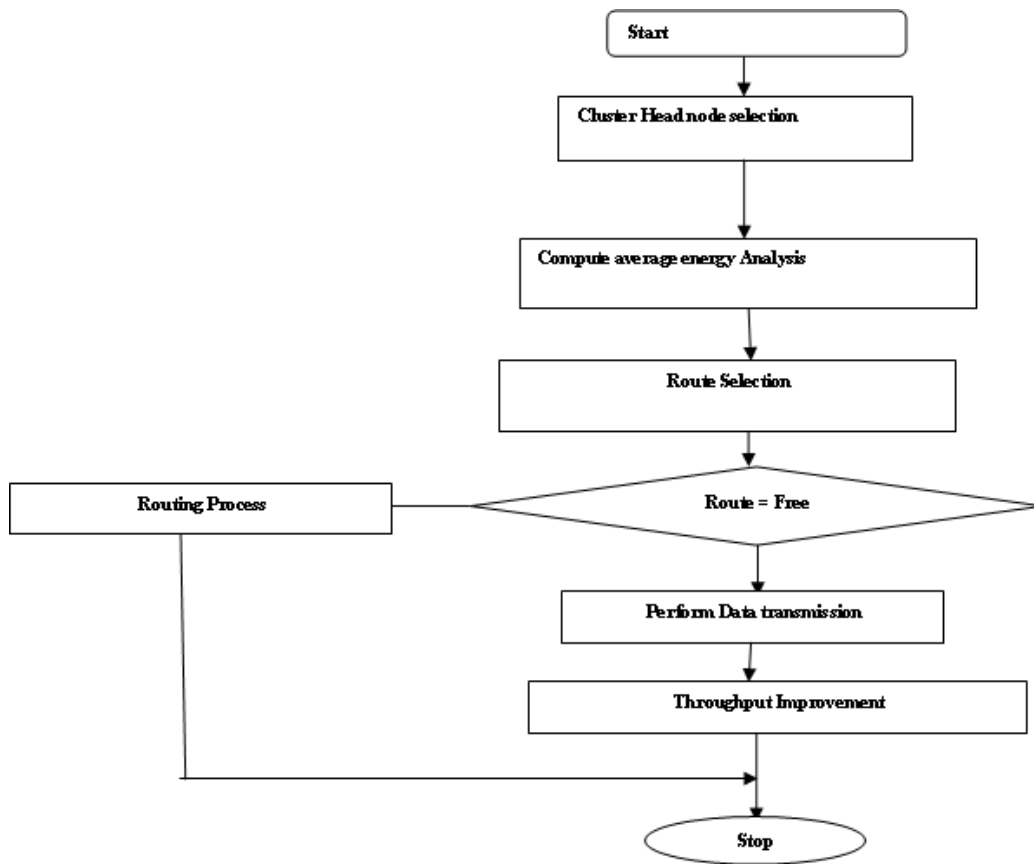

Fig. 5: Flow chart of energy-based route selection

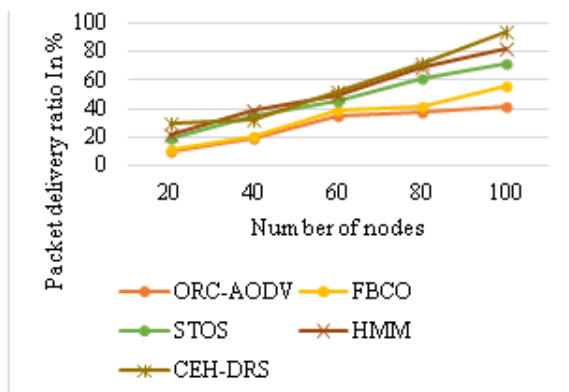

Fig. 6: Comparative Analysis

### 3.3 Throughput Ratio

Overall network performance is named as throughput ratio, it considers all the QoS parameter to conclude the result in the network.

Table 3 demonstrates the throughput proportion examination of the suggested framework in the network.

**Table 2: End-to-end delay**

The rate of sending packets/sec	ORC-AODV	FBCO	STOS	HMM	CEH-DRS
10	2.985	3.254	2.548	1.254	0.987
20	5.621	6.712	5.254	4.214	3.874
30	6.258	7.587	6.895	5.874	4.125
40	7.635	8.985	7.121	6.584	5.852
50	8.548	9.584	8.958	7.568	6.587

**Table 3: Analysis table**

No.of nodes	ORC-AODV in %	FBCO in %	STOS in %	HMM in %	CEH-DRS in %
20	15	17	22	39	42
40	19	25	36	45	53
60	35	39	45	62	78
80	41	45	65	79	82
100	49	56	72	86	91

Fig. 8 demonstrates the qualifying examination of the throughput proportion of the arranged structure with staying in the light of the qualities.

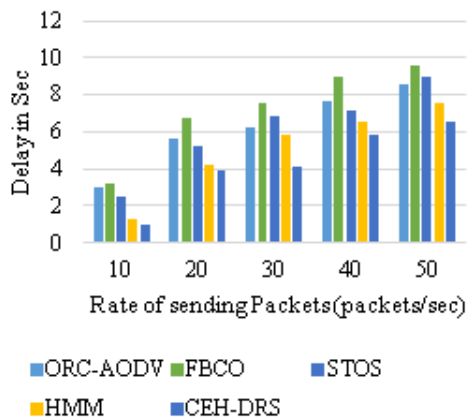

Fig. 7: End-to-end delay ratio

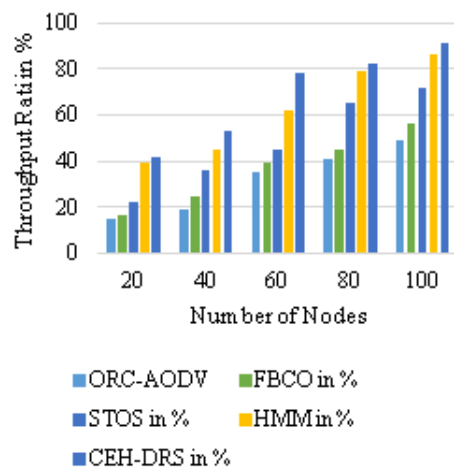

Fig. 8: Throughput ratio analysis

Finally, our Cluster Energy Hop Based Dynamic Route Selection (CEH-DRS) proposed method gives 94% of the delivery ratio as well as to gives 91% throughput ratio in the network.

## 4 Conclusion

We have proposed Cluster Energy Hop Based Dynamic Route Selection (CEH-DRS) routing way to deal with locating the best route in the network. The cluster head approach uses the node position-based discovery and dynamic routing strategies to perform identification of the cluster head. The cluster-based approach recognizes not just the starting point of risk and identifies an arrangement of traded-off nodes which support the head node and the varied estimation strategies discovering the risk network. At long last, the proposed ways to deal with performing close recognition of right and secure path and creating effective outcomes.

## References

- [1] T.C. Chiang, C.H. Liu and Y.M. Huang, A near-optimal multicast scheme for mobile adhoc networks using a hybrid genetic algorithm, \*Expert Systems with Applications\*, Elsevier, **33**(3) 734–742 (2007).
- [2] Chien-Chung Shen and Chaiporn Jaikaeo, AdHoc Multicast Routing Algorithm with Swarm Intelligence, *Mobile Networks and Applications*, **10**(1) 47–59 (2005).
- [3] G. Feng and C. Makki, Heuristic and exact algorithms for QoS routing with multiple constraints, *IEICE Transactions on Communications*, **E85-B**(12) 2838–2850 (2002).
- [4] R. Forsati, A.T. Haghighat and M. Mahdavi, Harmony search based algorithms for bandwidth-delay-constrained least-cost multicast routing, *Computer Communications*, **31**(10) 2505–2519 (2008).
- [5] A.H. Gandomi and A.H. Alavi, Krill herd: a new bio-inspired optimization algorithm, *Communications in Nonlinear Science and Numerical Simulation*, **17**(12) 4831–4845 (2012).
- [6] Mohamed Haddad and Paul Muhlethaler, Using Road IDs to Enhance Clustering in Vehicular Ad-hoc Networks, *Proceedings of IEEE International Wireless Communications and Mobile Computing Conference (IWCMC)*, 285–290 (2015).
- [7] Huaqing Lin and Zheng Yan, A Survey on Network Security-Related Data Collection Technologies, *IEEE Transaction network*, **6** 18345–18365 (2018).
- [8] Chao Gui, Yue Zeng, Bing Yan, Multiple constraints QoS multicast routing optimization algorithm in MANET based on GA, *Progress in Natural Science*, Elsevier Limited and Science in China Press, **18**(3), 331–336 (2008).
- [9] S. Bitam and Mellouk Bee life-based multi constraints multicast routing optimization for vehicular adhoc networks, *Journal of Network and Computer Applications*, **36**(3), 981–991 (2012).
- [10] Samarth Gupta and Vikas Upadhyay, Automated Vehicle Detection Using Optical Fiber Communication, *IEEE Sensors* **5**(3), 222–230 (2016).
- [11] Guoguang Chen, Distortion Analysis for Real-Time Data Collection of Correlated Fields in Randomly Distributed Sensor Networks, *IEEE*, **5**(2), 237–242 (2008)
- [12] Al Islam and Vijay Raghunathan, Evaluating Q-Learning Based Stateful Round Trip Time Estimation over High-Data-Rate Wireless Sensor Networks, *Proceedings in 16th IEEE Int'l Conf. Computer and Information Technology*, 136–141 (2014).
- [13] Antonio Capone Giuliana Carello, Brunilde Sanso, Energy Management Through Optimized Routing and Device Powering for Greener Communication Networks, *IEEE/ACM Transactions on Networking*, **22**(1), 313–325 (2014).
- [14] D. Rhee. S. Seetharam. Liu, Techniques for Minimizing Power Consumption in Low Data-Rate WSNs, in *Proceeding of IEEE Wireless Communications GA, USA*, **3**, 1727–1731 (2004).
- [15] S. Guo and T. He, Robust multi-pipeline scheduling in low-duty-cycle wireless sensor networks, in *INFOCOM, 2012 Proceedings IEEE*, Orlando Florida, 361–369 (2012).
- [16] U. Venkanna, Jeh Krishna Agarwal and R. Leela Velusamy, A Cooperative Routing for MANET based on Distributed



Trust and Energy Management, Springer, *Wireless Pers Commun*, **81**, 961–979 (2015).

- [17] A.M. Natarajan. and N. Annitha, A quality of service based AODV with QoS- aware routing algorithms for MANETs, *International Journal of Application or Innovation in Engineering & Management (IJAIEM)*, **2**(2), 199–204 (2013).
- [18] Mario Di Francesco, Giuseppe Anastasi, Data Collection in Wireless Sensor Networks with Mobile Elements: A Survey, *ACM Transactions on Sensor Networks*, **8**(1) (2012).
- [19] Yanchao Zhang, ARSA: An Attack-Resilient Security Architecture for Multihop Wireless Mesh Networks, *IEEE Journal on Selected Areas in Communications*, **24**(10), 1916–1928 (2006).
- [20] Human Wang, Beizhan Wang, Yaping Wang and Jiajun Wang, Energy-aware and self- adaptive anomaly detection scheme based on network tomography in mobile ad hoc networks, Elsevier, *Information Sciences*, **220**(1), 580–602 (2005).



**J. Sundararajan** received the B.E. degree in Electronics and Communication Engineering from Bharathiyar University, Coimbatore and M.Tech in Bio Medical Signal Processing and Instrumentation from Sastra University, Thanjavur. In 2008, he received his Ph.D.

degree in Information and Communication Engineering from Anna University, Chennai. From August 1992 to May 2003, he worked as an Assistant Professor. Since June 2003, he had been a Professor and Head of the Department. Moreover, he is working as Principal in Pavaï College of Technology, Namakkal, Tamilnadu, India, since 2009. He is a Life member in BMESI from 2002 to till date. Furthermore, his research interests include; Communication Network Design, Wireless Sensor Networks, Bio Medical Signal Processing, Embedded System, Medical Image Processing & networking.



**M. Sudha** obtained her Bachelor's Degree in Electronics and Communication Engineering from Madras University, Chennai. She received her M.B.A. degree in Finance from Alagappa University, Karaikkudi. Then, she obtained her M.E

degree in Applied Electronics from Anna University, Coimbatore. At present, she is pursuing her Research in the Information and Communication Engineering at Anna University, Coimbatore. Currently, she is an assistant professor in the Department of Electronics and Communication Engineering at Paavai Engineering College, Namakkal, Tamilnadu, India. Furthermore, her research interests include wireless sensor networks, Power management, Routing protocols, mobile ad-hoc networks, vehicular ad-hoc network and embedded-systems.